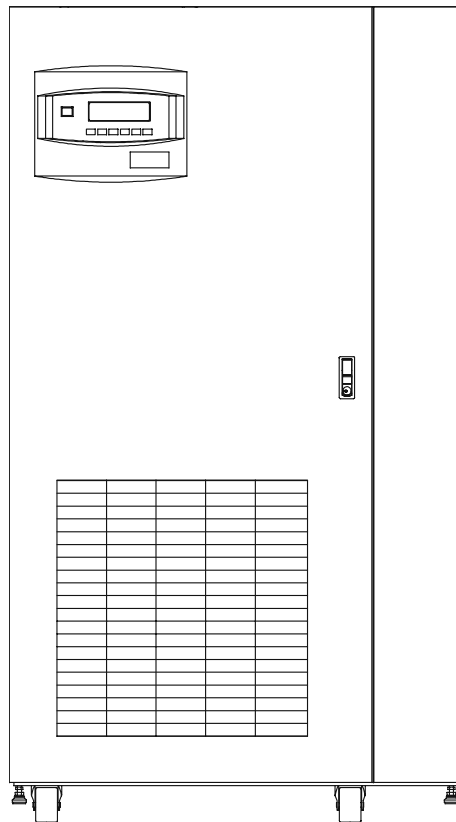


Npower™ UPS

INSTALLATION MANUAL



*30-130 kVA, 60 Hz
Single Module Systems
1+1 Redundant Systems*

The following **WARNING** applies to battery cabinets supplied with UPS systems:



WARNING

HAZARD

INTERNAL BATTERY STRAPPING MUST BE VERIFIED BY MANUFACTURER PRIOR TO MOVING A BATTERY CABINET FROM ITS INITIAL INSTALLATION LOCATION.

Battery cabinets contain non-spillable batteries.

Keep units upright.

Do not stack.

Do not tilt.

Failure to heed this warning could result in smoke, fire or electric hazard. Call 1-800-LIEBERT prior to moving battery cabinets from their initial installation location.

BEFORE YOU CALL...

If you require assistance for any reason, call Liebert Global Services at 1-800-543-2378. For LGS to assist you expediently, please have the following information available:

Part Numbers: _____
Serial Numbers: _____
kVA Rating: _____
Date Purchased: _____
Date Installed: _____
Location: _____
Input Voltage: _____
Bypass Voltage: _____
Output Voltage: _____
Battery Reserve Time: _____

IMPORTANT SAFETY INSTRUCTIONS

Save These Instructions.

This manual contains important instructions that should be followed during installation of your Npower UPS and batteries.



WARNING

EXERCISE EXTREME CARE WHEN HANDLING UPS CABINETS TO AVOID EQUIPMENT DAMAGE OR INJURY TO PERSONNEL. THE UPS MODULE WEIGHT RANGES FROM 2,200 POUNDS (1,000 KG) TO 3,800 POUNDS (1,725 KG). THE BATTERY CABINETS WEIGH BETWEEN 1,600 POUNDS (725 KG) AND 5,050 POUNDS (3,000 KG).

LOCATE CENTER OF GRAVITY SYMBOLS BEFORE HANDLING EACH CABINET. TEST LIFT AND BALANCE THE CABINETS BEFORE TRANSPORTING. MAINTAIN MINIMUM TILT FROM VERTICAL AT ALL TIMES.

OPEN AREAS BETWEEN CASTERS AT THE BASE OF THE MODULES AND BATTERY CABINETS CAN BE USED FOR FORKLIFT USE. THESE SURFACES WILL SUPPORT THE UNIT ONLY IF THE FORKS ARE COMPLETELY BENEATH THE UNIT.

THE INNER BARRIER PANEL OF THE BATTERY CABINET IS A STRUCTURAL ELEMENT. DO NOT MOVE BATTERY CABINET IF THIS PANEL HAS BEEN REMOVED.

FOLLOW ALL BATTERY SAFETY PRECAUTIONS WHEN INSTALLING, CHARGING, OR SERVICING BATTERIES. IN ADDITION TO THE HAZARD OF ELECTRIC SHOCK, GAS PRODUCED BY BATTERIES CAN BE EXPLOSIVE AND SULFURIC ACID CAN CAUSE SEVERE BURNS.

IN CASE OF FIRE INVOLVING ELECTRICAL EQUIPMENT, ONLY CARBON DIOXIDE FIRE EXTINGUISHERS, OR THOSE APPROVED FOR USE IN ELECTRICAL FIRE FIGHTING, SHOULD BE USED.

EXTREME CAUTION IS REQUIRED WHEN PERFORMING MAINTENANCE.

BE CONSTANTLY AWARE THAT THE UPS SYSTEM CONTAINS HIGH DC AS WELL AS AC VOLTAGES.

CHECK FOR VOLTAGE WITH BOTH AC AND DC VOLTMETERS PRIOR TO MAKING CONTACT.



WARNING

LOCATE CENTER OF GRAVITY SYMBOLS AND DETERMINE UNIT WEIGHT BEFORE HANDLING CABINET.



Table of Contents

1.0	SAFETY PRECAUTIONS	1
2.0	INSTALLATION CONSIDERATIONS	2
3.0	UNLOADING AND HANDLING	4
4.0	INSPECTIONS	
4.1	External Inspections	6
4.2	Internal Inspections	6
5.0	EQUIPMENT LOCATION	
5.1	General Instructions	7
5.2	Special Considerations for 1+1 Redundant Systems	7
6.0	BATTERY INSTALLATION	
6.1	Battery Safety Precautions	8
6.2	Matching Battery Cabinets	11
6.3	Non-Standard Batteries	12
7.0	CONFIGURING YOUR NEUTRAL AND GROUND CONNECTIONS	
7.1	Grounding for A/B or G/H UPS Models, Wye Source, 3-Wire Loads	14
7.2	Grounding for A/B or G/H UPS Models, Wye Source, 4-Wire Loads	15
7.3	Grounding for D/E or K/L UPS Models, Delta or Wye Source, 4-Wire Loads	16
7.4	Grounding for R/S or X/Y UPS Models, Delta Source, 3-Wire Loads	17
7.5	Grounding for A/B or G/H UPS Models, 1+1 Configuration	18
7.6	Grounding for D/E or K/L UPS Models, 1+1 Configuration	19
7.7	Grounding for R/S or X/Y UPS Models, 1+1 Configuration	20
7.8	Grounding for 2 Npower UPS Modules feeding a Static Transfer Switch	21
7.9	Grounding Configurations, Battery Systems	21
8.0	WIRING CONSIDERATIONS	
8.1	Power Wiring	23
8.2	Control Wiring	24
8.3	Battery Wiring	25
9.0	WIRING CONNECTIONS	26
10.0	WIRING INSPECTION	28
11.0	INSTALLATION DRAWINGS	30
12.0	APPENDIX A: SITE PLANNING DATA	85

List of Figures

Figure 1	Npower UPS modules, left-to-right: 30-50 kVA, 65-80 kVA and 100-130 kVA	3
Figure 2	Front view, Npower UPS module on pallet	5
Figure 3	Top view, Npower UPS module on pallet	5
Figure 4	Grounding Diagram, A/B or G/H UPS Models, Wye Source, 3-Wire Loads	14
Figure 5	Grounding Diagram, A/B or G/H UPS Models, Wye Source, 4-Wire Loads	15
Figure 6	Grounding Diagram, D/E or K/L UPS Models, Delta or Wye Source, 4-Wire Loads	16
Figure 7	Grounding Diagram, R/S or X/Y UPS Model, Delta Source, 3-Wire Loads	17
Figure 8	Grounding Diagram, A/B or G/H UPS Models, 1+1 Configuration	18
Figure 9	Grounding Diagram, D/E or K/L UPS Models, 1+1 Configuration	19
Figure 10	Grounding Diagram, R/S or X/Y UPS Models, 1+1 Configuration	20
Figure 11	Outline Drawing, 30-50 kVA UPS	30
Figure 12	Outline Drawing, 65-80 kVA UPS	31
Figure 13	Outline Drawing, 100-130 kVA UPS	32
Figure 14	Outline Drawing, Battery Power Pack, 25-Inch Cabinet	33
Figure 15	Outline Drawing, Battery Power Pack, 49-Inch Cabinet	34
Figure 16	Outline Drawing, Maintenance Bypass Cabinet, “L” Configuration	35
Figure 17	Outline Drawing, Maintenance Bypass Cabinet, “N” Configuration	36
Figure 18	Outline Drawing, Maintenance Bypass Cabinet, “P” Configuration	37
Figure 19	Outline Drawing, Maintenance Bypass Cabinet, “Q” Configuration	38
Figure 20	Outline Drawing, Slimline Distribution Cabinet, Top Cable Exit, Panelboards Only	39
Figure 21	Outline Drawing, Slimline Distribution Cabinet, Bottom Cable Exit, Panelboards Only	40
Figure 22	Outline Drawing, Slimline Distribution Cabinet, with Panelboard and Subfeed Breakers	41
Figure 23	Outline Drawing, Slimline Distribution Cabinet, with 100-250A Subfeed Breakers Only	42
Figure 24	Outline Drawing, Slimline Distribution Cabinet, with 300-400A Subfeed Breakers Only	43
Figure 25	Specifications Table, 1+1 Paralleling Panelboard Configuration “N”	44
Figure 26	Outline Drawing, 1+1 Paralleling Panelboard, Configuration “N,” Size “A”	45
Figure 27	Outline Drawing, 1+1 Paralleling Panelboard, Configuration “N,” Size “B”	46
Figure 28	Outline Drawing, 1+1 Paralleling Panelboard, Configuration “N,” Size “C”	47
Figure 29	Outline Drawing, Seismic Anchoring, 30-50 kVA UPS	48
Figure 30	Outline Drawing, Seismic Anchoring, 65-80 kVA UPS	49
Figure 31	Outline Drawing, Seismic Anchoring, 100-130 kVA UPS	50
Figure 32	Outline Drawing, Remote Battery Breaker 30 - 130 kVA	51
Figure 33	Outline Drawing, Remote Battery Breaker with Motor Operator, 30 - 130 kVA	52
Figure 34	Outline Drawing, Remote Battery Breaker with BIB Installed	53
Figure 35	Outline Drawing, Remote Alarm Status Panel	54
Figure 36	Outline Drawing, LBS Control Panel	55
Figure 37	Outline Drawing, LBS Alarm Status Contacts	56
Figure 38	Outline Drawing, LBS Transformer Panel	57
Figure 39	Control Wiring, LBS Interconnection Wiring Diagram for Configs A, B, R, S	58
Figure 40	Control Wiring, LBS Interconnection Wiring Diagram for Configs D, E	59
Figure 41	Control Wiring, 30 - 130 kVA UPS	60
Figure 42	Control Wiring, 1+1 Category 5 Patch Cable Connection	61
Figure 43	Control Wiring, 1+1 Twisted-Pair Cable Connection	62
Figure 44	Control Wiring, Remote Alarm Status Panel Option	63
Figure 45	Control Wiring, 2 or 3 Remote Alarm Status Panels	64
Figure 46	Control Wiring, 3 Remote Alarm Status Panels with Stub Connections	65
Figure 47	Control Wiring, Site Scan Interface	66

Figure 48	Control Wiring, Programmable Relay Board Option	67
Figure 49	Control Wiring, Input Contact Isolator Board	68
Figure 50	Control Wiring, NIC Option	69
Figure 51	Control Wiring, Power Supply Option	70
Figure 52	Control Wiring, Internal Modem Option	71
Figure 53	Control Wiring, AS 400 Signal Cable Option	72
Figure 54	Control Wiring, Open Wire Cable Adaptor Option	73
Figure 55	Control Connection Diagram 50 --130 kVA	74
Figure 56	Control Connection Location Diagram, 30-130 kVA UPS	75
Figure 57	Terminal Details, 30 - 50 kVA UPS	76
Figure 58	Terminal Details, 65 - 80 kVA UPS	77
Figure 59	Terminal Details, 100 - 130 kVA UPS	78
Figure 60	Schematic Diagram Maintenance Bypass Interlock System	79
Figure 61	Schematic Diagram Maintenance Bypass Interlock System with EPO	80
Figure 62	Line-Up Detail Maintenance Bypass and Distribution Cabinets	81
Figure 63	Wiring Diagram, UPS with Single Battery Cabinet	82
Figure 64	Interconnection Diagram, UPS Module with Multiple Battery Cabinets	83
Figure 65	Circuit Breaker Schedule, Maintenance Bypass Cabinet, 30 - 130 kVA	84

List of Tables

Table 1	Power Wiring Terminals - Factory Supplied	28
Table 2	Torque Specifications	28
Table 3	Table 310-16.	29

1.0 SAFETY PRECAUTIONS

Read this manual thoroughly, paying special attention to the sections that apply to you, before working with the UPS. **Retain this manual for use by installing personnel.**

Under typical operation and with all UPS doors closed, only normal safety precautions are necessary. The area around the UPS system should be kept free from puddles of water, excess moisture, or debris.

Special safety precautions are required for procedures involving handling, installation, and maintenance of the UPS system or the battery. Observe all safety precautions in this manual before handling or installing the UPS system. Observe all precautions in the **Operation and Maintenance Manual**, before as well as during performance of all maintenance procedures. Observe all battery safety precautions before working on or near the battery.

This equipment contains several circuits that are energized with high voltage. Only test equipment designated for troubleshooting should be used. This is particularly true for oscilloscopes. Always check with an AC and DC voltmeter to ensure safety before making contact or using tools. Even when the power is turned Off, dangerously high potentials may exist at the capacitor banks and at the batteries.

ONLY qualified service personnel should perform maintenance on the UPS system.

When performing maintenance with any part of the equipment under power, service personnel and test equipment should be standing on rubber mats. The service personnel should wear insulating shoes for isolation from direct contact with the floor (earth ground).

Unless all power is removed from the equipment, one person should never work alone. A second person should be standing by to assist and summon help in case an accident should occur.

Four types of messages are used throughout the manual to stress important text. Carefully read the text below each Danger, Warning, Caution, and Note and use professional skills and prudent care when performing the actions described by that text.

A **Danger** signals immediate hazards resulting in severe personal injury or death. For example:



DANGER

A DANGER SIGNALS IMMEDIATE HAZARDS WHICH WILL RESULT IN SEVERE PERSONAL INJURY OR DEATH.

A **Warning** signals the presence of a possible serious, life-threatening condition. For example:



WARNING

LETHAL VOLTAGES MAY BE PRESENT WITHIN THIS UNIT EVEN WHEN IT IS APPARENTLY NOT OPERATING. OBSERVE ALL CAUTIONS AND WARNINGS IN THIS MANUAL. FAILURE TO DO SO COULD RESULT IN SERIOUS INJURY OR DEATH. DO NOT WORK ON OR OPERATE THIS EQUIPMENT UNLESS YOU ARE FULLY QUALIFIED TO DO SO!! NEVER WORK ALONE.

A **Caution** indicates a condition that could seriously damage equipment and possibly injure personnel. For example:



CAUTION

Extreme care is necessary when removing shoring braces. Do not strike the cabinet with hammers or other tools.

A **Note** emphasizes important text. If the note is not followed, equipment could be damaged or may not operate properly. For example:



NOTE

If the UPS system has a blown fuse, the cause should be determined before you replace the fuse. Contact Liebert Global Services.

2.0 INSTALLATION CONSIDERATIONS

Install your Npower UPS in accordance with the submittal drawing package and the following procedures. The submittal package is supplied by the Liebert Sales Representative.

A Liebert authorized representative must perform the initial system check-out and start-up to ensure proper system operation. Equipment warranties will be voided unless system start-up is performed by a Liebert authorized representative. Contact your local Liebert sales representative or Liebert Global Services at **1-800-543-2378** to arrange for system start-up.



CAUTION

Read this manual thoroughly before attempting to wire or operate the unit. Improper installation is the most significant cause of UPS start-up problems.

Do not install this equipment near gas or electric heaters. It is preferable to install the UPS in a restricted location to prevent access by unauthorized personnel.

1. Proper planning will speed unloading, location, and connection of the UPS. **Refer to Figure 11 through Figure 37 and Appendix A: Site Planning Data.**
2. Refer to information later in this manual regarding the optional Battery Cabinets. **Observe all battery safety precautions when working on or near the battery.**
3. Use the shortest output distribution cable runs possible, consistent with logical equipment arrangements and with allowances for future additions if planned.
4. Recommended ambient operating temperature is 25°C (77°F). Relative humidity must be less than 95%, non-condensing. Note that room ventilation is necessary, but air conditioning may not be required. Maximum ambient operating temperature is 40°C (104°F) without derating. At elevations above 6,500 feet (2,000 meters) derating may be required (consult your Liebert sales representative).
5. Ambient temperature of the batteries should not exceed 25°C (77°F). Higher ambient temperatures can cause significantly reduced battery life.
6. The standard Npower must be used with external overcurrent protection devices on the input, the output and (when applicable) the bypass. Please refer to **Appendix A: Site Planning Data** for required ratings of these devices.
7. During normal UPS operations, short-term current demand from the bypass AC input source may reach ten times the rated output current rating. The instantaneous trip settings of the upstream bypass AC input feeder breaker(s) must be set accordingly.
8. Even though your Liebert UPS unit is highly efficient, the heat output of any 3-phase UPS can be substantial. For more specific information, see **Appendix A: Site Planning Data**. Be sure environmental conditioning systems can accommodate this BTU load, even during utility outages.
9. The routing (inside the facility) to the installation site, as well as the floor at the final equipment location, must be capable of supporting the cabinet weight and the weight of any moving equipment. Refer to **Appendix A: Site Planning Data** for specific product weights.
10. Plan the routing to ensure that the unit can move through all aisleways, doorways, and around corners without risking damage. If the modules and batteries must be moved by elevator, check the size of the door openings and the weight-carrying capacity of the elevator.



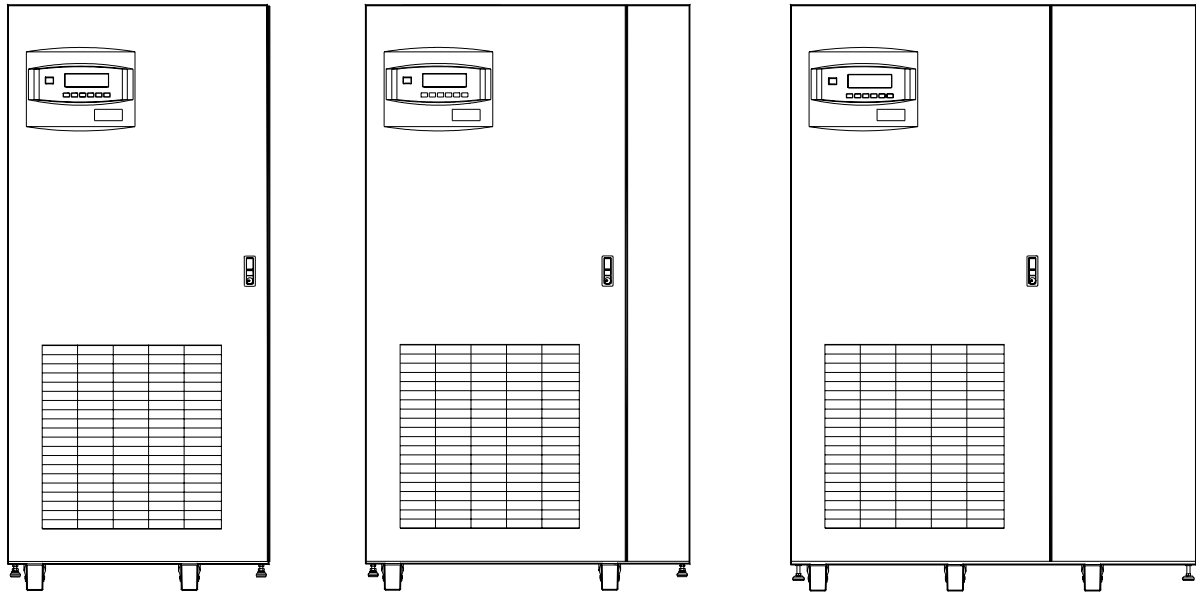
CAUTION

The inner barrier panel at the front of the Battery Cabinet is a structural member. If the barrier panel has been removed for inspection or service, do not move the Battery Cabinet until the barrier panel has been replaced.



WARNING
LOCATE CENTER OF GRAVITY SYMBOLS AND DETERMINE
UNIT WEIGHT BEFORE HANDLING CABINETS.

Figure 1 Npower UPS modules, left-to-right: 30-50 kVA, 65-80 kVA and 100-130 kVA



3.0 UNLOADING AND HANDLING

The UPS module is shipped in one cabinet to allow easy handling at the site. Because the weight distribution in the cabinet is uneven, use extreme care during handling and transport. Your installation may also include Battery Cabinets, Maintenance Bypass Cabinets and a SlimLine Distribution Cabinet..



WARNING

EXERCISE EXTREME CARE WHEN HANDLING UPS CABINETS TO AVOID EQUIPMENT DAMAGE OR INJURY TO PERSONNEL. THE UPS MODULE WEIGHT RANGES FROM 2,200 POUNDS TO 3,800 POUNDS. BATTERY CABINETS WEIGH BETWEEN 1,600 AND 5,050 POUNDS.

LOCATE CENTER OF GRAVITY SYMBOLS BEFORE HANDLING CABINET. TEST LIFT AND BALANCE THE CABINET BEFORE TRANSPORTING. MAINTAIN MINIMUM TILT FROM VERTICAL AT ALL TIMES, NOT TO EXCEED 15 DEGREES.

THE MODULE AND BATTERY CABINETS CAN BE MOVED BY FORKLIFT. THE FORKS SHOULD BE INSERTED BETWEEN THE CASTER WHEEL ASSEMBLIES. FORKS MUST BE EXTENDED THE FULL DEPTH OF THE CABINET TO PROPERLY SUPPORT THE EQUIPMENT.



NOTE

To reduce the possibility of shipping damage, UPS cabinets are secured to the pallet as shown in the drawings at right. These packing elements must be carefully removed before attempting to remove the module from the pallet. Please follow these steps:

- *Cut the metal banding straps and remove.*
- *Unbolt and remove the four corner brackets retaining the 2x4 boards.*
- *Use forklift to remove module from pallet.*



CAUTION

Use extreme care not to strike the UPS cabinet when removing strapping and brackets.

Figure 2 Front view, Npower UPS module on pallet

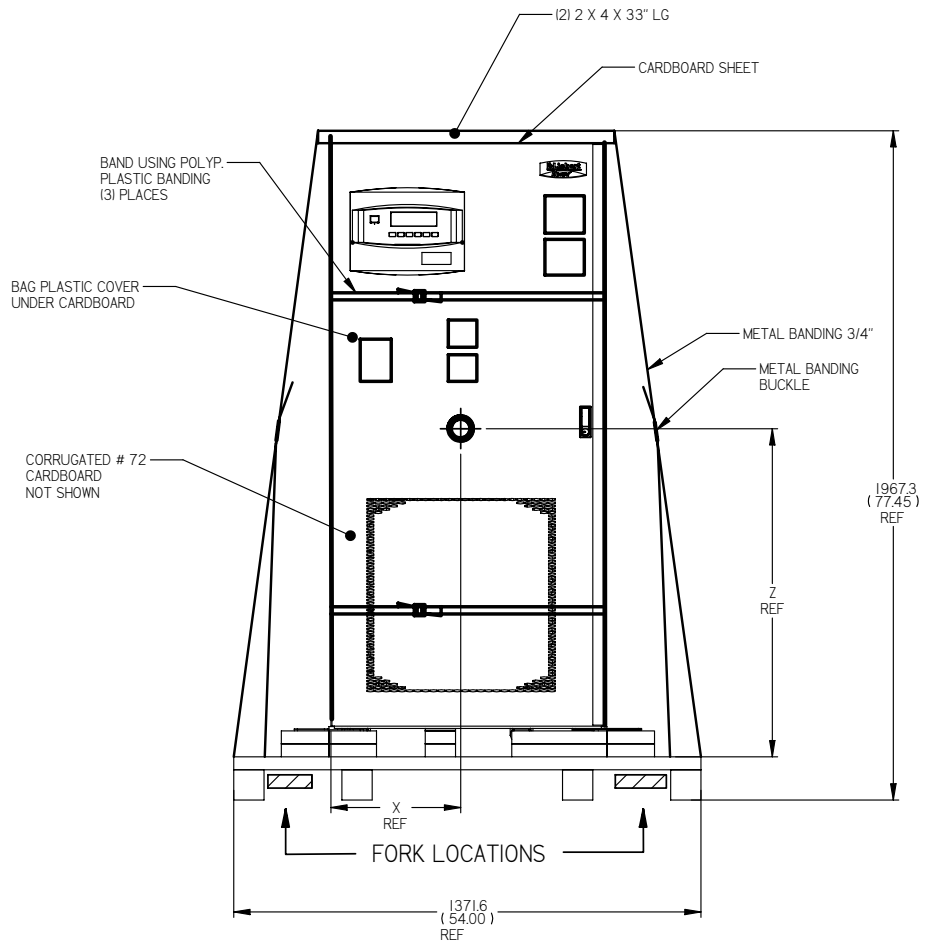
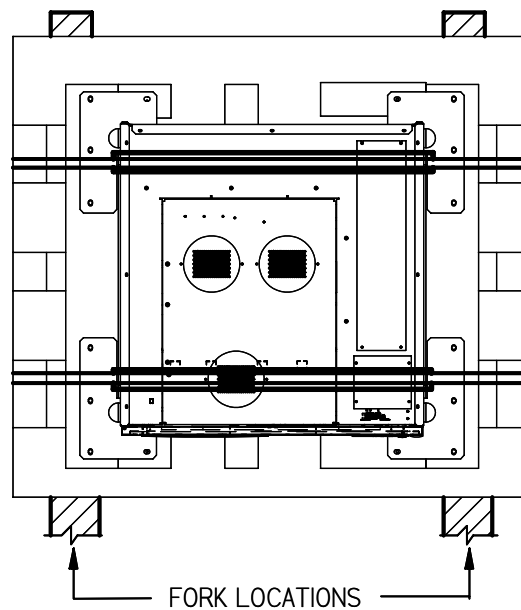


Figure 3 Top view, Npower UPS module on pallet



4.0 INSPECTIONS

4.1 External Inspections

1. While the UPS system is still on the truck, inspect the equipment and shipping container(s) for any signs of damage or mishandling. Do not attempt to install the system if damage is apparent. If any damage is noted, file a damage claim with the shipping agency within 24 hours and contact Liebert Global Services at 1-800-543-2378 to inform them of the damage claim and the condition of the equipment.
2. Locate the bag containing the keys for the front access door. The bag is attached to the cabinet.
3. Compare the contents of the shipment with the bill of lading. Report any missing items to the carrier and to Liebert Global Services immediately.
4. Check the nameplate on the cabinets to verify that the model numbers correspond with the one specified. Record the model numbers and serial numbers in the front of this installation manual. A record of this information is necessary should servicing become required.

4.2 Internal Inspections

1. Verify that all items have been received.
2. If spare parts were ordered, verify arrival.
3. Open doors and remove cabinet panels to check for shipping damage to internal components.
4. Check for loose connections or unsecured components in the cabinet(s).
5. Check for any unsafe condition that may be a potential safety hazard.

5.0 EQUIPMENT LOCATION

5.1 General Instructions

1. Handle cabinet(s) in accordance with the safety precautions in Section 1.0. If necessary, use a suitable material handling device to remove cabinet from the shipping pallet. **Exercise extreme care because of the uneven weight distribution.** Carefully lower the cabinet to the floor. The casters should enable the UPS to be pushed to the installation location.
2. Verify that the UPS system is installed in a clean, cool and dry location.
3. Installation and serviceability will be easier if adequate access is provided on all sides of the equipment, but only front access is required.
 - a. Verify that there is adequate clearance to open cabinet doors. See drawings and local codes. Liebert recommends 3 feet (or 1 meter) of service clearance.
 - b. Verify that there is adequate area in front of cabinet to perform maintenance. Check with local codes.
 - c. Verify that there is adequate clearance above all cabinets to allow exhaust air to flow without restriction (2 feet minimum, unobstructed). If power and control wiring are routed into the top of the UPS, ensure that the conduit or wireway does not obstruct removal of the UPS top panel.



NOTE

The UPS has leveling feet to prevent the UPS from rolling on its casters after installation. The leveling feet are not designed to carry the full weight of the UPS. Turn the feet by hand until “finger-tight” against the floor. Then tighten a small amount with a wrench (less than two turns) to give a good friction fit against the floor. When using seismic anchoring, ensure that the casters are bearing the weight of the UPS.



NOTE

The Npower Battery Cabinet comes in versions specific to either the left or right side of the UPS. Control wires and power cables are cut to different lengths for the different versions. For systems with multiple battery cabinets, the cabinets have different part numbers indicating placement of the cabinet relative to the UPS. An “A” or “1” designation means the cabinet is adjacent to the UPS. Cabinet “B” will be adjacent to cabinet “A” and cabinet “C” (if applicable) will adjacent to cabinet “B.”



NOTE

If the system includes a matching Npower Maintenance Bypass Cabinet (MBC), the MBC is generally attached to the right side of the UPS, closest to the UPS bus bars. The Battery Cabinet(s) would then be mounted to the left side of the UPS. However, both the MBC and Battery Cabinets are available in both left-side and right-side configurations to meet site-specific requirements.

5.2 Special Considerations for 1+1 Redundant Systems

1. Consider the grounding configuration of your system before finalizing module placement. For optimal grounding performance, the Npower modules should be close together.
2. For optimal load-sharing performance, the UPS output power cables should be approximately the same length, plus-or-minus 20 percent.
3. Position modules in such a way as to minimize the length of power cables and control wiring between UPS modules and the paralleling cabinet.
4. Battery cabinets should generally be positioned to the left side of the UPS modules, to make it easier to connect the UPS output bus bars to the Paralleling Cabinet or Panelboard.

6.0 BATTERY INSTALLATION

6.1 Battery Safety Precautions

Servicing of batteries should be performed or supervised by personnel knowledgeable of batteries and the required precautions. Keep unauthorized personnel away from batteries.

When replacing batteries, use the same number and type of batteries.



CAUTION

Lead-acid batteries contain hazardous materials. Batteries must be handled, transported, and recycled or discarded in accordance with federal, state, and local regulations. Because lead is a toxic substance, lead-acid batteries should be recycled rather than discarded.

Do not open or mutilate the battery or batteries. Released electrolyte is harmful to the skin and eyes. It may be toxic. Do not dispose of battery or batteries in a fire. The battery may explode.

A battery can present a risk of electrical shock and high short circuit current. The following precautions should be observed when working on batteries:

- 1. Remove watches, rings, or other metal objects.**
- 2. Use tools with insulated handles.**
- 3. Wear rubber gloves and boots.**
- 4. Do not lay tools or metal parts on top of batteries.**
- 5. Disconnect charging source prior to connecting or disconnecting battery terminals.**
- 6. Determine if battery is inadvertently grounded. If inadvertently grounded, remove source of ground. Contact with any part of a grounded battery can result in electrical shock. The likelihood of such shock will be reduced if such grounds are removed during installation and maintenance.**

Lead-acid batteries can present a risk of fire because they generate hydrogen gas. The following procedures should be followed:

- 1. DO NOT SMOKE when near batteries.**
- 2. DO NOT cause flame or spark in battery area.**
- 3. Discharge static electricity from body before touching batteries by first touching a grounded metal surface.**

Battery Safety Precautions in French Per CSA Requirements

Instructions Importantes Concernant La Sécurité

Conserver Ces Instructions



ADVERTISSEMENT

DES PIÈCES SOUS ALIMENTATION SERONT LAISSÉES SANS PROTECTION DURANT CES PROCÉDURES D'ENTRETIEN. UN PERSONNEL QUALIFIÉ EST REQUIS POUR EFFECTUER CES TRAVAUX.

LES FUSIBLES A C.C. DE LA BATTERIE D'ACCUMULATEURS OPÈRENT EN TOUT TEMPS A LA TENSION NOMINALE. LA PRÉSENCE D'UN FUSIBLE A C.C. BRÛLE INDIQUE UN PROBLÈME SÉRIEUX. LE REMPLACEMENT DE CE FUSIBLE, SANS AVOIR DÉTERMINÉ LES RAISONS DE LA DÉFECTUOSITÉ, PEUT ENTRAÎNER DES BLESSURES OU DES DOMMAGES SÉRIEUX À L'ÉQUIPEMENT. POUR ASSISTANCE, APPELER LE DÉPARTEMENT DE SERVICE À LA CLIENTÈLE DE LIEBERT.



DANGER

Les accumulateurs plomb-acide contiennent de la matière comportant un certain risque. Les accumulateurs doivent être manipulés, transportés et recyclés ou éliminés en accord avec les lois fédérales, provinciales et locales. Parce que le plomb est une substance toxique, les accumulateurs plomb-acide devraient être recyclés plutôt qu'éliminés.

Il ne faut pas brûler le ou les accumulateurs. L'accumulateur pourrait alors exploser.

Il ne faut pas ouvrir ou endommager le ou les accumulateurs. L'électrolyte qui pourrait s'en échapper est dommageable pour la peau et les yeux.

Un accumulateur représente un risque de choc électrique et de haut courant de court-circuit. Lorsque des accumulateurs sont manipulés, les mesures préventives suivantes devraient être observées:

- 1. Retirer toutes montres, bagues ou autres objets métalliques.**
- 2. Utiliser des outils avec manchon isolé.**
- 3. Porter des gants et des bottes de caoutchouc.**
- 4. Ne pas déposer les outils ou les pièces métalliques sur le dessus des accumulateurs.**
- 5. Interrompre la source de charge avant de raccorder ou de débrancher les bornes de la batterie d'accumulateurs.**
- 6. Déterminer si l'accumulateur est mis à la terre par erreur. Si oui, défaire cette mise à la terre. Tout contact avec un accumulateur mis à la terre peut se traduire en un choc électrique. La possibilité de tels chocs sera réduite si de telles mises à la terre sont débranchées pour la durée de l'installation ou de l'entretien.**

Les accumulateurs plomb-acide présentent un risque d'incendie parce qu'ils génèrent des gaz à l'hydrogène. Les procédures suivantes devront être respectées.

- 1. NE PAS FUMER** lorsque près des accumulateurs.
- 2. NE PAS produire de flammes ou d'étincelles** près des accumulateurs.
- 3. Décharger toute électricité statique présente sur votre corps avant de toucher un accumulateur en touchant d'abord une surface métallique mise à la terre.**



DANGER

L'électrolyte est un acide sulfurique dilué qui est dangereux au contact de la peau et des yeux. Ce produit est corrosif et aussi conducteur électrique. Les procédures suivantes devront être observées:

- 1. Porter toujours des vêtements protecteurs ainsi que des lunettes de protection pour les yeux.**
- 2. Si l'électrolyte entre en contact avec la peau, nettoyer immédiatement en rinçant avec de l'eau.**
- 3. Si l'électrolyte entre en contact avec les yeux, arroser immédiatement et généreusement avec de l'eau. Demander pour de l'aide médicale.**
- 4. Lorsque l'électrolyte est renversée, la surface affectée devrait être nettoyée en utilisant un agent neutralisant adéquat. Une pratique courante est d'utiliser un mélange d'approximativement une livre (500 grammes) de bicarbonate de soude dans approximativement un gallon (4 litres) d'eau. Le mélange de bicarbonate de soude devra être ajouté jusqu'à ce qu'il n'y ait plus apparence de réaction (mousse). Le liquide résiduel devra être nettoyé à l'eau et la surface concernée devra être asséchée.**

6.2 Matching Battery Cabinets

Two sizes of optional battery cabinets are available. Refer to **Figure 14** and **Figure 15**. The same model battery cabinet may be paralleled in multiple cabinet strings for additional capacity. Battery capacity (in minutes) at your installation will depend on cabinet model, number of cabinets, and amount of critical load on the UPS.

1. **Handling.** The Battery Cabinet has casters to facilitate movement over short distances. The bottoms of the Battery Cabinets are reinforced to permit movement by forklift over longer distances.
2. **Cabinet Inspection.** Remove all panels and visually inspect the batteries, bus connections, and cabinet for any damage. **Exercise caution; voltage is present within the Battery Cabinet even before installation.** If there are signs of damage, do not proceed. Call Liebert Global Services at 1-800-542-2378.
3. **Battery Storage.** The batteries used in the Battery Cabinet have an excellent charge retaining characteristic. The batteries can be stored for up to six months without any appreciable deterioration. Self-discharge rate of the batteries is approximately 3% per month when the batteries are stored in temperatures of 15°C to 25°C (59°F to 77°F). If the Battery Cabinet is planned to be stored for longer than six months or at temperatures higher than 25°C, contact Liebert Customer Service for recommended action.
4. **Installation.** The Battery Cabinet(s) can be located conveniently next to each UPS module, and are also available in stand-alone configurations with painted side panels. The front-access-only-design eliminates side and rear service clearance requirements.
 - **Environment.** Locate the Battery Cabinet in a clean, dry environment. Recommended temperature range for optimum performance and lifetime is 20°C (68°F) to 25°C (77°F).
 - **Position.** The Npower Battery Cabinet comes in versions specific to either the left or right side of the UPS. Control wires and power cables are cut to different lengths for the different versions. For systems with multiple battery cabinets, the cabinets have different part numbers indicating placement of the cabinet relative to the UPS. An “A” or “1” designation means the cabinet is adjacent to the UPS. Cabinet “B” will be adjacent to cabinet “A” and cabinet “C” (if applicable) will adjacent to cabinet “B.” If the system includes a matching Maintenance Bypass Cabinet (MBC), the MBC should be mounted to the right of the UPS (nearest the bus bars) and the battery cabinet(s) should be installed to the left of the UPS. Likewise left-side placement of the battery cabinet is preferable for 1+1 systems.
 - **Service Clearance.** Allow front access to the Battery Cabinet at all times for maintenance and servicing. Electrical codes require that the Battery Cabinet be installed with no less than 3 feet (1 meter) of clearance at the front of the cabinet when operating. Side and rear panels do not require service clearance.
 - **Cables.** Cables may be run between the cabinets through cutouts in the top of the cabinet, eliminating the need for external conduit runs. **Route cables before moving cabinets into final position for bolting together.** Remove top panels for access, if required. No top or bottom entry cables are required, except for remotely located cabinets which require conduits. Refer to **Figure 14**, **Figure 15** and **Figure 33**.
 - **Bolt-On Cabinets.** Matching Battery Cabinets are designed to bolt onto the side of the UPS module cabinet. Use bolts (3/8"-16 x 1-1/4") to connect cabinet frames at posts, two places front and two places rear. As mentioned above, stand-alone cabinets are also available.
 - **Software Consideration.** The number of battery cabinets must be noted when performing initial startup and setup on the UPS screen.
 - **Casters and Leveling Feet.** The leveling feet are not designed to bear the full weight of the cabinet. Lower the feet until they are “finger-tight” in contact with the floor. Then tighten a small amount with a wrench (less than two turns) to give a good friction fit. When mounting the battery cabinet on seismic stands, ensure that the casters are bearing the weight of the cabinet.
 - **Battery Support Tray.** Be sure to connect the Battery Support Tray to the front of the cabinet before sliding a battery tray out for connection or service. Without the Support Tray in place, the weight of the batteries could cause the tray to fall out of the cabinet. See **Figure 14** and **Figure 15** for details.

6.3 Non-Standard Batteries

When batteries other than a matching Battery Cabinet are used, a remote battery disconnect switch with overcurrent protection is required per the National Electrical Code. Contact your Liebert sales representative regarding this option.

1. Install battery racks/cabinets and batteries per manufacturer's installation and maintenance instructions.
2. Verify battery area has adequate ventilation and battery operating temperature complies with manufacturer's specification.

If you have any questions concerning batteries, battery racks, or accessories, contact Liebert Global Services at 1-800-543-2378.

7.0 CONFIGURING YOUR NEUTRAL AND GROUND CONNECTIONS

Improper grounding is the largest single cause of UPS installation and start-up problems. This is not a simple subject, since grounding techniques vary significantly from site to site, depending on several factors. The two main concerns are the configuration of the Npower UPS and the type of load connected to the UPS.

- **Npower UPS Configuration.** The Npower can be ordered with an optional isolated neutral for sites that do not have grounded-ye (4-wire + ground) source power available. If the building service is straight delta or corner-grounded delta, the Npower UPS must be configuration D/E or R/S (K/L or X/Y for models with input isolation transformers). The UPS configuration is the 12th digit in the model number, or 4th digit from the right.



NOTE

It is important to inform your Liebert sales representative if your site has anything except solidly grounded wye input, so the isolated-neutral configuration can be ordered. This configuration cannot be created in the field by modifying a standard UPS.

- **“3-Wire” vs. “4-Wire” Loads.** The simplest loads are “3-wire” -- those which require the three phase conductors plus the ground conductor. Typical 3-wire loads are Power Distribution Units (PDUs) containing isolation transformers. “4-wire” loads are those which require the three phase conductors plus the ground conductor plus a neutral conductor. Typical 4-wire loads are transformerless PDUs supporting single-phase (phase-to-neutral) loads.

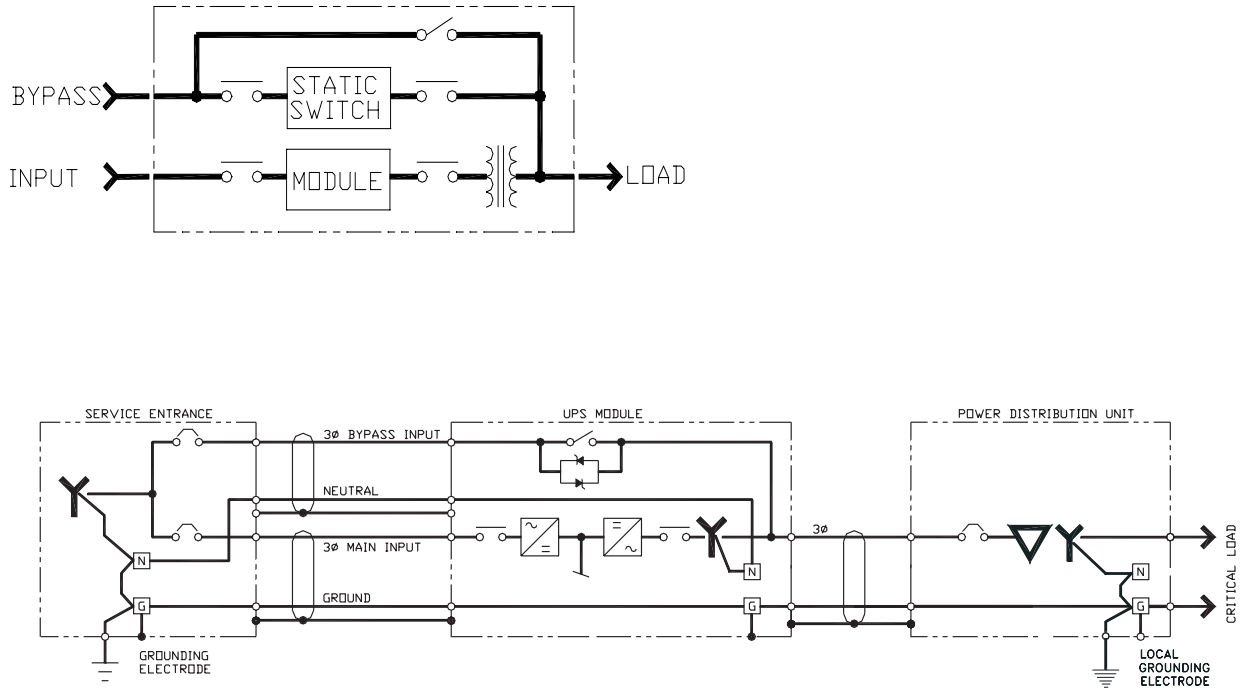
The following sections discuss recommended grounding procedures for various system configurations.



NOTES

- 1. UPS modules with matching Maintenance Bypass Cabinets are generally grounded exactly like those that do not have them. However, if the Maintenance Bypass Cabinet includes a Bypass Isolation Transformer, the neutral-to-ground bond will be made inside the Bypass Cabinet. The Maintenance Bypass Cabinet neutral will be solidly connected to the UPS neutral. The customer power terminations will be made in the Maintenance Bypass Cabinet instead of in the UPS module.*
- 2. Some UPS modules are equipped with input isolation transformers. However, these transformers have no effect upon any system grounding considerations. These modules will be grounded exactly as shown in the following examples.*
- 3. All the diagrams on the following pages depict dual-input UPS modules, for clarity. Single-input UPS modules are grounded exactly the same way.*
- 4. Every conduit or bus duct carrying phase wiring into or out of the UPS must also contain a grounding conductor. Solid-metal conduit is not a suitable grounding conductor for the Npower UPS or its connected loads. In particular, a grounding conductor must be in the conduit bringing the phase conductors from the service entrance.*

Figure 4 Grounding Diagram, A/B or G/H UPS Models, Wye Source, 3-Wire Loads



7.1 Grounding for A/B or G/H UPS Models, Wye Source, 3-Wire Loads

A common configuration of Npower UPS is with 480 VAC input, 480 VAC output, and a connected load consisting of one or more Power Distribution Units (PDUs) with isolation transformers in the PDUs to produce 208 VAC. For Canadian customers, the UPS modules usually have 600 VAC input and output. The same principles apply if the connected load is an isolation transformer feeding various loads. **Figure 4** above shows a typical installation.

Notice that the UPS input is connected to a grounded-wye service. In this configuration, the critical load does not require a neutral from the UPS. However, the UPS neutral is solidly connected to the service-entrance neutral, and there is no neutral-to-ground bond at the UPS. The installing contractor must bring a neutral conductor from the service entrance to the UPS neutral.

The isolation transformer in the PDU is a separately derived source. Therefore the PDU neutral should be bonded to the PDU ground terminal and connected to a local grounding electrode in compliance with NEC.

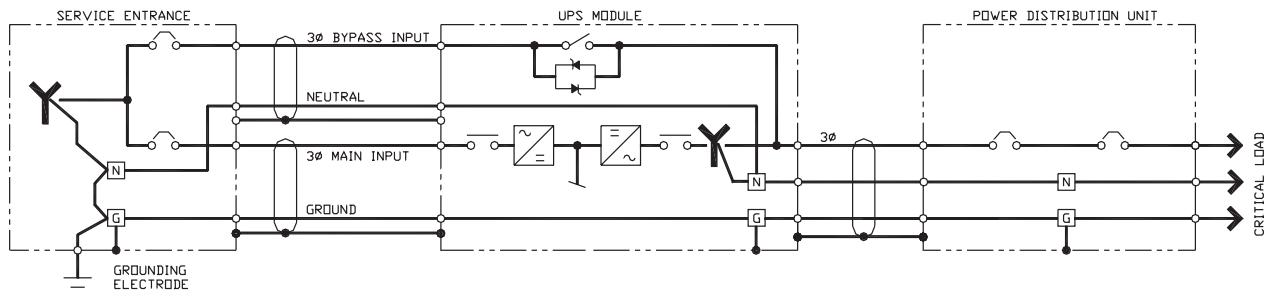
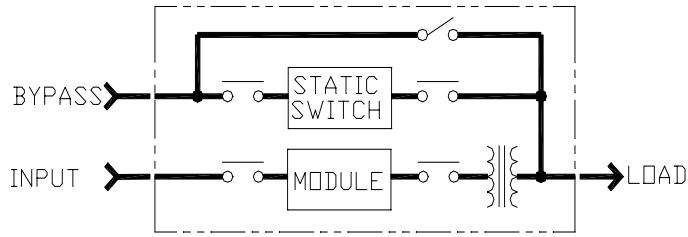
This UPS system may include a Maintenance Bypass Cabinet. The Maintenance Bypass Cabinet neutral will be solidly connected to the UPS output neutral, which will be solidly connected to the service-entrance neutral.



NOTES

Ungrounded and corner-grounded delta sources require that the Npower be furnished from the factory with an Isolated Load Neutral, as described in later sections.

Figure 5 Grounding Diagram, A/B or G/H UPS Models, Wye Source, 4-Wire Loads



7.2 Grounding for A/B or G/H UPS Models, Wye Source, 4-Wire Loads

This configuration is common in applications where the UPS input is 208 VAC and the load is a PDU (or a bolt-on Slim Line Distribution Unit) directly powering phase-to-neutral (4-wire) loads.

This configuration is similar to that shown in Section 7.1 because the installing contractor must bring a neutral conductor from the service entrance to the UPS neutral.

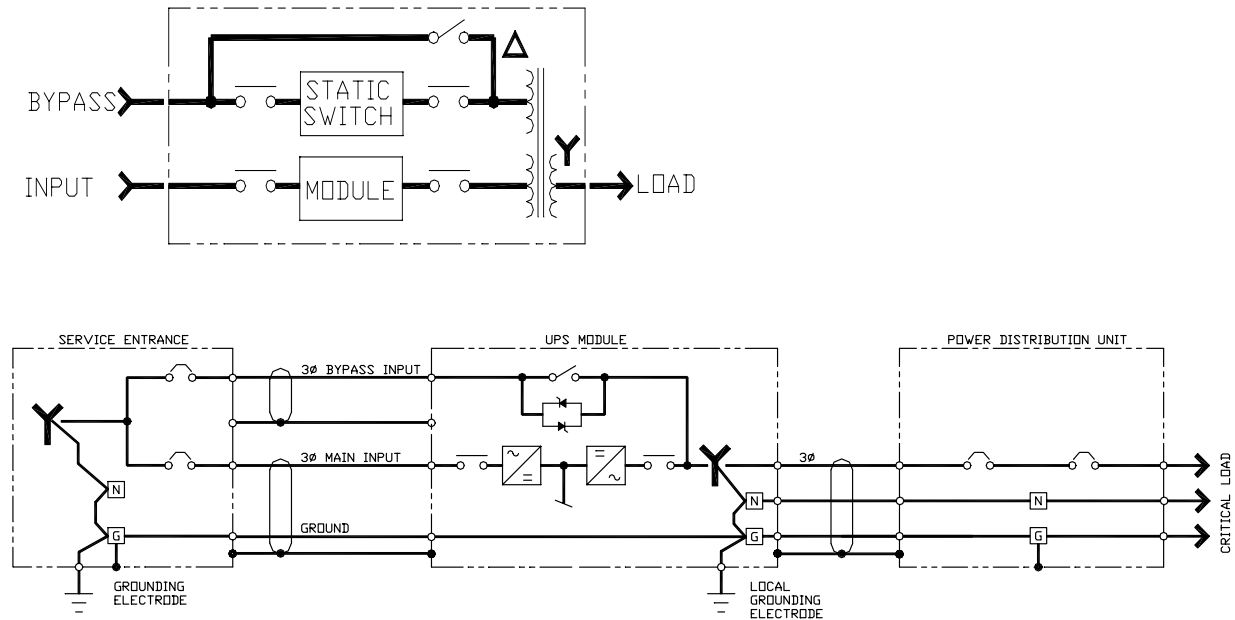
This UPS system may include a Maintenance Bypass Cabinet. The Maintenance Bypass Cabinet neutral will be solidly connected to the UPS output neutral, and will also be solidly connected to the service entrance neutral.



NOTES

Ungrounded and corner-grounded delta sources require that the Npower be furnished from the factory with an Isolated Load Neutral, as described in later sections.

Figure 6 Grounding Diagram, D/E or K/L UPS Models, Delta or Wye Source, 4-Wire Loads



7.3 Grounding for D/E or K/L UPS Models, Delta or Wye Source, 3- or 4-Wire Loads

The D/E and K/L models have the isolated load neutral, and can be used in any 3-wire or 4-wire application. In this case, the UPS neutral is solidly connected to the UPS ground, and a local grounding electrode is installed in accordance with the NEC.

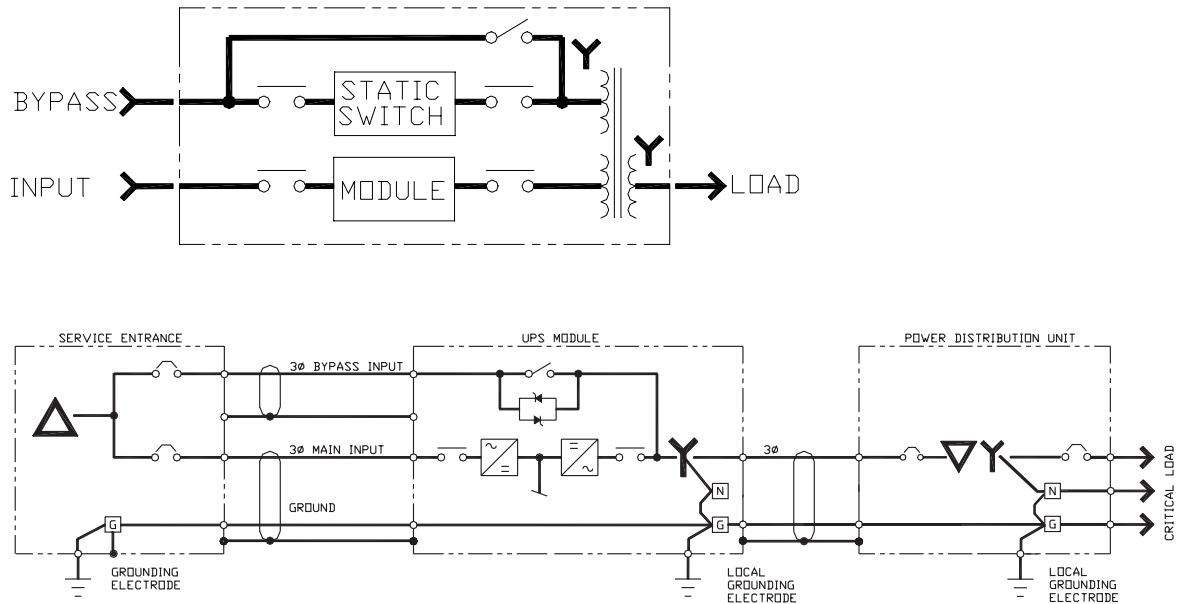
This UPS system may include a Maintenance Bypass Cabinet containing a Bypass Isolation Transformer. The Bypass Isolation Transformer neutral will be bonded to its ground. The UPS output neutral will be solidly connected to the Bypass Isolation Transformer neutral.



NOTES

Ground-Fault Interrupters should be set to tolerate approximately 30 cycles (500 milliseconds) of recirculating current that may be present during transfer and retransfer operations.

Figure 7 Grounding Diagram, R/S or X/Y UPS Model, Delta Source, 3-Wire Loads



7.4 Grounding for R/S or X/Y UPS Models, Delta Source, 3-Wire Loads

If building service is ungrounded delta or corner-grounded delta, the Npower UPS must have the isolated load neutral.

In this case, the UPS neutral is solidly connected to the UPS ground, and a local grounding electrode is installed in accordance with the NEC.

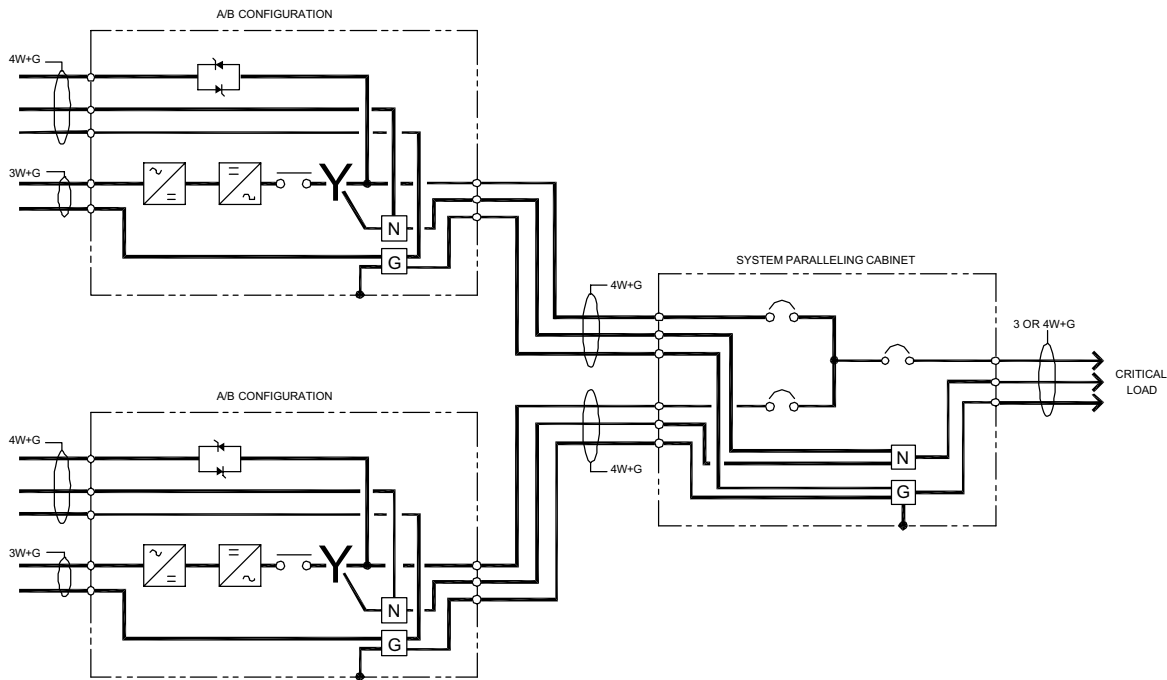
This UPS system may include a Maintenance Bypass Cabinet containing a Bypass Isolation Transformer. The Bypass Isolation Transformer neutral will be bonded to its ground. The UPS output neutral will be solidly connected to the Bypass Isolation Transformer neutral.



NOTES

1. The R/S and X/Y models can only support 3-wire loads.
2. Ground-Fault Interrupters should be set to tolerate approximately 30 cycles (500 milliseconds) of recirculating current that may be present during transfer and retransfer operations.

Figure 8 Grounding Diagram, A/B or G/H UPS Models, 1+1 Configuration



7.5 Grounding for A/B or G/H UPS Models, 1+1 Configuration

There are two methods for grounding A/B or G/H models in a 1+1 configuration. One option, shown above, is an extension of the configuration shown in **Figures 4 and 5**, where each UPS module is solidly connected to the building service neutral. Both UPS module neutrals are then solidly connected to the Paralleling Cabinet Neutral. This option is especially applicable when an existing A/B or G/H installation is upgraded to the 1+1 configuration. For three-wire loads, it is not necessary to connect a neutral conductor to the Paralleling Cabinet. For four-wire loads, each UPS module neutral will need to be solidly connected to the Paralleling Cabinet neutral.

The other option (not shown) for supporting four-wire loads is to run a single neutral conductor from the service entrance to the Paralleling Cabinet neutral. Both UPS modules will then have their output neutrals solidly connected to the Paralleling Cabinet neutral.

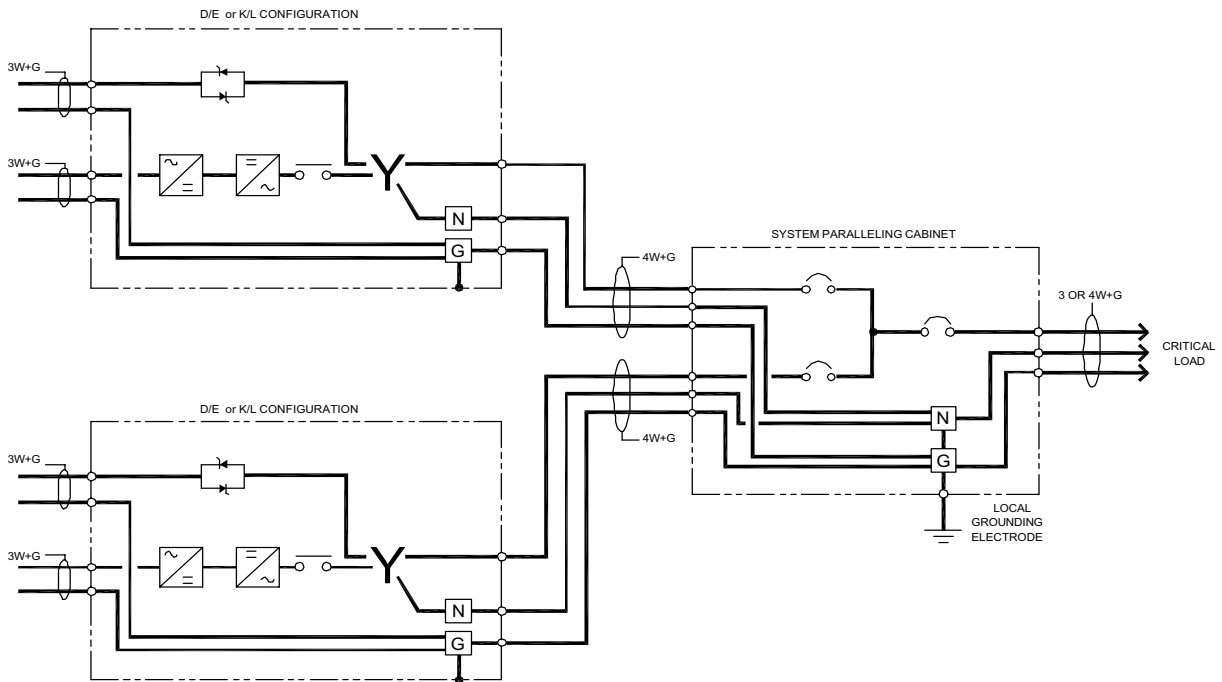
For either configuration, there must *not* be a neutral-to-ground bond inside the Paralleling Cabinet or inside either UPS module.



NOTES

Both UPS modules must share a common bypass source.

Figure 9 Grounding Diagram, D/E or K/L UPS Models, 1+1 Configuration



7.6 Grounding for D/E or K/L UPS Models, 1+1 Configuration

When using D/E or K/L models in a 1+1 Configuration, both UPS modules will have their output neutrals solidly connected to the Paralleling Cabinet neutral. The neutral-to-ground bond *must* be located inside the Paralleling Cabinet. There *must not* be a neutral-to-ground bond in either UPS module.

Although not pictured above, a local grounding electrode must be installed at the Paralleling Cabinet.

This configuration will support either 3-wire or 4-wire loads.

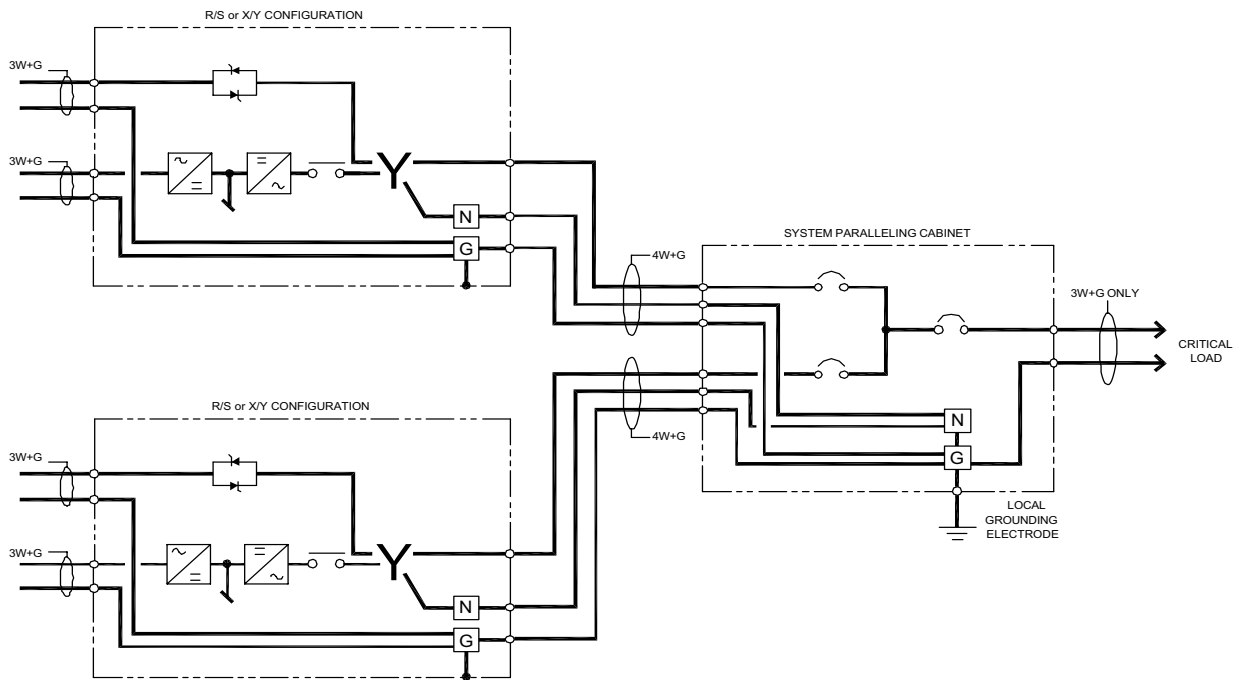


NOTES

1. D/E and K/L UPS modules normally ship with a neutral-to-ground bond inside the UPS. Verify that this bond has been removed from both modules before connecting the modules to the Paralleling Cabinet.

2. Ground-Fault Interrupters should be set to tolerate approximately 30 cycles (500 milliseconds) of recirculating current that may be present during transfer and retransfer operations.

Figure 10 Grounding Diagram, R/S or X/Y UPS Models, 1+1 Configuration



7.7 Grounding for R/S or X/Y UPS Models, 1+1 Configuration

When using R/S or X/Y models in a 1+1 configuration, the UPS module neutrals are solidly connected to the Paralleling Cabinet neutral. The neutral-to-ground bond *must* be located inside the Paralleling Cabinet. There *must not* be a neutral-to-ground bond inside either UPS module.

Although not pictured above, a local grounding electrode must be installed at the Paralleling Cabinet.

This configuration will only support 3-wire loads.



NOTES

1. R/S and X/Y UPS modules normally ship with a neutral-to-ground bond inside the UPS. Verify that this bond has been removed from both modules before connecting the modules to the Paralleling Cabinet.
2. Ground-Fault Interrupters should be set to tolerate approximately 30 cycles (500 milliseconds) of recirculating current that may be present during transfer and retransfer operations.

7.8 Grounding for 2 Npower UPS Modules feeding a Static Transfer Switch

Any version of Npower UPS module can be applied in a dual-bus (distributed redundant) configuration. Both Npower modules will be grounded exactly as shown in **Figure 4** through **Figure 7** of this manual.

The recommended configuration is to have each UPS module provide 3-wires+ground to an isolation transformer on the input of the Static Transfer Switch. The neutrals of the two isolation transformers will be solidly connected, and bonded to the ground of one transformer. A local grounding electrode will then be applied to the bonded transformer.

At this time, Liebert does not support having two Npower modules provide 4-wire input directly to the Static Transfer Switch to directly support 208Y/120 VAC loads on the output of the Static Transfer Switch.

7.9 Grounding Configurations, Battery Systems

Large, open-rack battery systems are normally locally grounded. Refer to the code requirements for your region.

Battery cabinet frames, on the other hand, should be grounded to the UPS module ground busbar. For systems with multiple cabinets, the installer can connect all the battery cabinet grounds together and run a single ground conductor to the UPS module ground busbar.

8.0 WIRING CONSIDERATIONS



WARNING

ALL POWER CONNECTIONS MUST BE COMPLETED BY A LICENSED ELECTRICIAN THAT IS EXPERIENCED IN WIRING THIS TYPE OF EQUIPMENT. WIRING MUST BE INSTALLED IN ACCORDANCE WITH ALL APPLICABLE NATIONAL AND LOCAL ELECTRICAL CODES. IMPROPER WIRING MAY CAUSE DAMAGE TO THE EQUIPMENT OR INJURY TO PERSONNEL.

VERIFY THAT ALL INCOMING HIGH AND LOW VOLTAGE POWER CIRCUITS ARE DE-ENERGIZED AND LOCKED OUT BEFORE INSTALLING CABLES OR MAKING ANY ELECTRICAL CONNECTIONS.

Refer to **Appendix A: Site Planning Data** and installation drawings (**Figure 11** through **Figure 37**). Determine AC currents for your system (kVA, voltage, and options). Also refer to equipment nameplate for the model number, rating, and voltage. Refer to **Table 1** and **Table 2** for wire termination data.



NOTE

*Use 75°C copper wire. Select wire size based on the ampacities in **Table 3** of this manual, a reprint of Table 310-16 and associated notes of the National Electrical Code (NFPA 70).*



NOTE

Interconnecting control wiring should be run in a separate conduit from the power wiring.



CAUTION

The weight of power cables must be adequately supported to avoid stress on bus bars and lugs. In addition to weight support, the following restraining method is recommended to control cable movement during external fault conditions: Wrap line cables together at 6 inches and 12 inches from the terminals with 5 wraps of 3/8 inch nylon rope or equivalent (tensile strength of 2000 pounds). Support remainder of cable with 5 wraps every 6 inches or 1 wrap every 1 inch.



NOTE

The Npower UPS requires site-furnished overcurrent protection devices for rectifier input, bypass input and UPS output. These devices can be ordered as part of the optional Maintenance Bypass Cabinet or furnished by the installing contractor.

8.1 Power Wiring

1. Power wiring must be run in individual, separate conduits or cable trays. Refer to the installation drawings (**Figure 11** to **Figure 36**) for locations of the various power connections within the UPS and ancillary cabinets. In particular, note the location of the various power connections.



CAUTION

Power and control wiring must be separated.

2. Observe local, state and national electrical codes. Verify utility power and its overcurrent protection rating will accommodate the UPS input rating, including battery recharging.
3. A safety ground wire must be run from building ground to the ground point in the UPS cabinets. See Sections 7.1 through 7.4. The grounding conductor shall comply with the following conditions of installation:
 - a. An insulated grounding conductor must be sized in accordance with the NEC and local codes. It must be green (with or without one or more yellow stripes) and be installed as part of the branch circuit that supplies the unit or system.
 - b. The grounding conductor described above is to be grounded to earth at the service equipment or, if supplied by a separately derived system, at the supply transformer or motor-generator set in accordance with the instructions in Section 7 of this Manual.
 - c. A grounding conductor must be supplied with the current-carrying conductors in each conduit.
 - d. The attachment-plug receptacles in the vicinity of the unit or system are all to be of a grounding type, and the grounding conductors serving these receptacles are to be connected to earth ground at the service equipment.
4. Observe clockwise phase rotation of all power wiring. Phase A leads Phase B leads Phase C. A qualified electrician should check the phase rotation.
5. Power cables must be rated for less than 2 volts line drop at maximum rated system current.
6. If site equipment includes a backup generator and automatic transfer switch(es), consult the manufacturers of those devices for information on sizing and interfacing to the UPS system.
7. The installing contractor can remove the access plates from the cable-access areas in the top and bottom of the UPS in order to cut entry holes for conduit..



CAUTION

After cutting holes in the access plates, be certain that no foreign matter (metal shavings, sawdust, insulation or wire fragments, etc.) remains inside the UPS. Likewise be certain to block any “extra” holes in the plates through which foreign matter (or rodents) could later enter the UPS.

8.2 Control Wiring

Control wiring must be stranded and tinned and run in individual separate steel conduits. Control wiring must be separated from power wiring. In addition, each control wiring cable group should be run in a separate conduit to minimize control signal interference.

If your system has any installed options, special wire lists will be included in your Submittal Drawing Package. Contact your Liebert Sales Representative for assistance if the submittal drawings have been lost or misplaced.

Figure 32 shows the typical location of control connections inside the UPS.



NOTE

The UPS control and communication wiring are considered Class 2 circuits by NEC standards. However, NEC Class 1 wiring methods are required for these circuits to ensure proper operation of the UPS.

8.3 Battery Wiring

Power wiring to the Battery Cabinet connects positive, negative, and ground power cables from the Battery Cabinet to the associated UPS. Connection of the UPS to the Battery Cabinet serves to both charge and discharge the batteries (when needed). The battery disconnect (circuit breaker) requires a control cable. Liebert Battery Cabinets that bolt to the UPS include power and control cables to join multiple cabinets together into a system. Additional (field-supplied) power or control wiring might be necessary to connect the battery cabinet system to the UPS.

When a site requires more than two battery cabinets, the Npower can be ordered with a Multiple Battery Breaker option. The option consists of a Multiple Battery Breaker (MBB) board that mounts on the control door and an Input Contact Isolator (ICI) board that mounts in the option area (See **Section 14** in the Options Manual.)

The ICI board allows the Npower system to sense multiple battery cabinets, and the MBB board allows the UPS to support multiple battery cabinets by supplying power to the UVR coil of additional battery cabinets.

Refer to **Figure 14**, **Figure 15**, **Figure 33** and **Figure 64**.



DANGER

A BATTERY INTERCELL CONNECTION ON EACH TIER OF THE LIEBERT BATTERY CABINET IS DISCONNECTED FOR SAFETY DURING SHIPMENT. DO NOT COMPLETE THESE CONNECTIONS. THE LIEBERT GLOBAL SERVICES REPRESENTATIVE WILL COMPLETE THESE CONNECTIONS AS PART OF START-UP. AN IMPROPERLY INSTALLED UNIT CAN RESULT IN INJURY TO PERSONNEL OR DAMAGE TO EQUIPMENT.



CAUTION

Be sure polarity is correct when wiring the Battery Cabinet to the connected equipment (positive to positive; negative to negative). If polarity is not correct, fuse failures or equipment damage can result.



CAUTION

DC power cables should be installed in conduit with conductors in matched pairs (positive and negative).



NOTE

A Liebert Battery Specialist can perform a detailed inspection of the entire battery system to ensure it meets current IEEE standards. This inspection service is recommended because batteries are a very critical part of the UPS system.

9.0 WIRING CONNECTIONS



DANGER

VERIFY THAT ALL INCOMING HIGH AND LOW VOLTAGE POWER CIRCUITS ARE DE-ENERGIZED AND LOCKED OUT BEFORE INSTALLING CABLES OR MAKING ELECTRICAL CONNECTIONS.

ALL POWER CONNECTIONS MUST BE COMPLETED BY A LICENSED ELECTRICIAN EXPERIENCED IN WIRING UPS EQUIPMENT, AND IN ACCORDANCE WITH ALL APPLICABLE NATIONAL AND LOCAL ELECTRICAL CODES.

IMPROPER WIRING MAY CAUSE DAMAGE TO THE UPS OR INJURY TO PERSONNEL.



CAUTION

All shielded cables, non-shielded cables, non-shielded control wires, non-shielded battery breaker control wires, and non-shielded remote control wires must be housed in individual, separate, steel conduits. Placing multiple cables in the same conduit with other control or power wiring may cause system failure.

Refer to the drawings in this manual and any other drawings provided by Liebert for this installation. Make all of the following connections:

1. Connect optional Maintenance Bypass Cabinets (if applicable) to the UPS module using the appropriate factory-furnished cables.
2. Connect AC power cables from input power source circuit breaker to the input terminals of either the Maintenance Bypass Cabinet (if applicable) or the UPS module. Observe phase rotation.
3. If this is a dual-input UPS system (separate AC and bypass inputs), connect AC power cables from bypass power source circuit breaker to UPS system bypass input -- either at the Maintenance Bypass Cabinet or at the UPS module. Observe phase rotation.



CAUTION

See Section 7 of this Manual for an explanation of proper grounding techniques.

4. Connect AC power cables from UPS module (or Maintenance Bypass Cabinet) output to either the Slim Line distribution cabinet or to the switchgear for critical load bus. Observe phase rotation.



NOTE

Make sure all required wiring between the UPS module and the optional cabinet(s) is completed. Observe phase rotation.

5. The UPS module output neutral is connected as shown in **Figure 4** through **Figure 7**, depending on the UPS configuration.



CAUTION

UPS bypass and system output neutral must be connected to only one common point in the UPS system. This neutral line must be grounded at the source.

6. For Battery Cabinets:
DC power cables (and ground) from Battery Cabinet to UPS Module, and between Battery Cabinets.

Observe polarity. DC power cables should be installed in matched pairs (positive and negative).



NOTE

DC power and battery circuit breaker control cables are provided with Liebert-brand Battery Cabinets that will be bolted to the UPS. Power cables are sized for interconnecting Battery Cabinets.



DANGER

DO NOT MAKE ANY CONNECTIONS BETWEEN BATTERY TIERS IN THE BATTERY CABINET. THESE CONNECTIONS WILL BE MADE BY THE LIEBERT CUSTOMER SERVICE REPRESENTATIVE DURING START-UP.

7. For remote battery, install DC power cables (and ground) from battery to Module Battery Disconnect, and then to UPS module DC bus. Observe polarity.
8. Connect Module Battery Disconnect control wiring to UPS module, and between Battery Cabinets if applicable.
9. Install wiring for control connections for the Maintenance Bypass.
10. Install power connections from critical bus switchgear to critical load bus. Observe phase rotation.
11. Install control wiring to Remote Monitor Panel or other communication options, if applicable. Wiring must be run in individual separate steel conduit.
12. Install Emergency Power Off control wiring in separate steel conduit.
13. Install any additional special wiring required at your site.

10.0 WIRING INSPECTION

1. Verify all power connections are tight.
2. Verify all control wire terminations are tight.
3. Verify all power wires and connections have proper spacing between exposed surfaces, phase-to-phase and phase-to-ground.
4. Verify that all control wires are run in individual, separate, steel conduit.

Table 1 Power Wiring Terminals - Factory Supplied

UPS Module Rating	Connection Type
30-130 kVA	Bus bars. See Outline Drawings for dimensions.
Use 75°C copper wire. Select wire size based on the ampacities in Table 310-16 (see Table 3 of this manual) and associated notes of the National Electrical Code (NFPA 70). Use commercially available solderless lugs for the wire size required for your application. Connect wire to the lug using tools and procedures specified by the lug manufacturer.	

Table 2 Torque Specifications

Nut and Bolt Combinations				
Bolt Shaft Size	Grade 2 Standard		Electrical Connections with Belleville Washers	
	Lb-in	N-m	Lb-in	N-m
1/4	53	6.0	46	5.2
5/16	107	12	60	6.8
3/8	192	22	95	11
1/2	428	48	256	29
Circuit Breakers With Compression Lugs (For Power Wiring)				
Cable Size or Range	Lb-in	N-m		
#6 - #4	100	11		
#3 - #1	125	14		
1/0 - 2/0	150	17		
3/0 - 200 MCM	200	23		
250 - 400 MCM	250	28		
500 - 700 MCM	300	34		
Terminal Block Compression Lugs (For Control Wiring)				
AWG Wire Size or Range	Lb-in	N-m		
#22 - #14	3.5 to 5.3	0.4 to 0.6		

Use the values in this table unless the equipment is labeled with a different torque value.

Table 3 Table 310-16

Allowable Ampacities of Insulated Conductors Rated 0-2000 Volts, 60° to 90°C (140° to 194°F)¹

Not More than Three Conductors in Raceway or Cable or Earth (Directly Buried), based on Ambient Temperature of 30° (86°F)

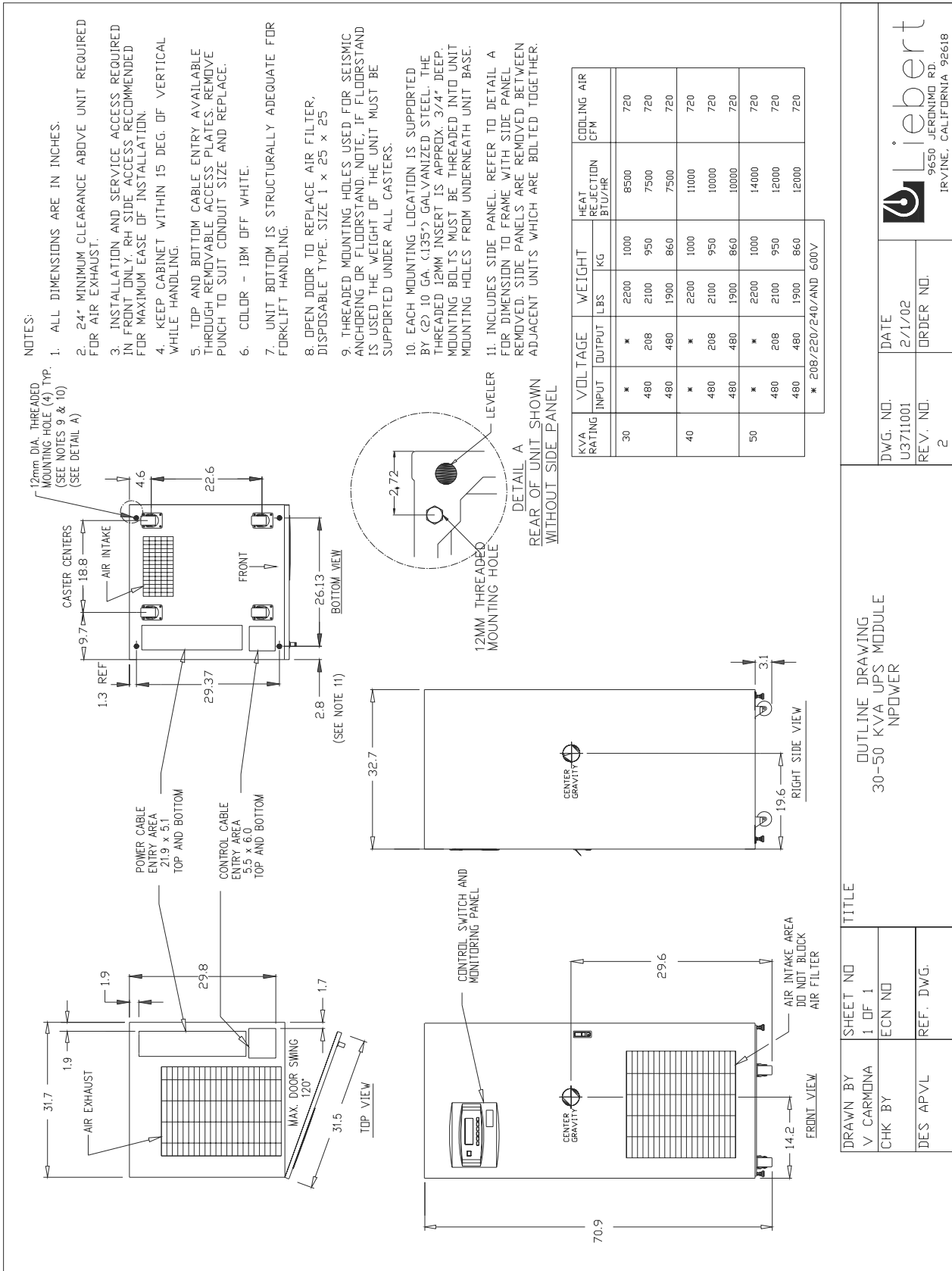
Size	Temperature Rating of Conductor. See Table 310-13.						Size
	60°C (140°F)	75°C (167°F)	90°C (194°F)	60°C (140°F)	75°C (167°F)	90°C (194°F)	
	Types TW* UF*	Types FEPW*, RH, RHW*, THHW*, THW*, THWN*, XHHW*, USE*, ZW*	Types TBS, SA, SIS FEP*, FEPB*, MI, RHH*, RHW-2, THHN*, THHW*, THW-2, THWN-2, USE-2, XHH, XHHW* XHHW-2, ZW-2	Types TW* UF*	Types RH*, RHW*, THHW*, THW*, THWN*, XHHW*, USE*	Types TBS, SA, SIS, THHN*, THHW*, THW-2, THWN-2, RHH*, RHW-2, USE-2, XHH, XHHW*, XHHW-2, ZW-2	
Copper			Aluminum or Copper-Clad Aluminum			AWG kcmil	
18	14
16	18
14	20†	20†	25†	20†	20†	25†	12
12	25†	25†	30†	25	25	35†	10
10	30	35†	40†	30	40	45	8
8	40	50	55				
6	55	65	75	40	50	60	6
4	70	85	95	55	65	75	4
3	85	100	110	65	75	85	3
2	95	115	130	75	90	100	2
1	110	130	150	85	100	115	1
1/0	125	150	170	100	120	135	1/0
2/0	145	175	195	115	135	150	2/0
3/0	165	200	225	130	155	175	3/0
4/0	195	230	260	150	180	205	4/0
250	215	255	290	170	205	230	250
300	240	285	320	190	230	255	300
350	260	310	350	210	250	280	350
400	280	335	380	225	270	305	400
500	320	380	430	260	310	350	500
600	355	420	475	285	340	385	600
700	385	460	520	310	375	420	700
750	400	475	535	320	385	435	750
800	410	490	555	330	395	450	800
900	435	520	585	355	425	480	900
1000	455	545	615	375	445	500	1000
1250	495	590	665	405	485	545	1250
1500	520	625	705	435	520	585	1500
1750	545	650	735	455	545	615	1750
2000	560	665	750	470	560	630	2000
Correction Factors							
Ambient Temp °C	For ambient temperatures other than 30°C (86°F), multiply the allowable ampacities shown above by the appropriate factor shown below.						Ambient Temp °F
21-25	1.08	1.05	1.04	1.08	1.05	1.04	70-77
26-30	1.00	1.00	1.00	1.00	1.00	1.00	78-86
31-35	.91	.94	.96	.91	.94	.96	87-95
36-40	.82	.88	.91	.82	.88	.91	96-104
41-45	.71	.82	.87	.71	.82	.87	105-113
46-50	.58	.75	.82	.58	.75	.82	114-122
51-55	.41	.67	.76	.41	.67	.76	123-131
56-6058	.7158	.71	132-140
61-7033	.5833	.58	141-158
71-804141	159-176

* Unless otherwise specifically permitted elsewhere in this Code, the overcurrent protection for conductor types marked with an asterisk (*) shall not exceed 15 amperes for No. 14, 20 amperes for No. 12, and 30 amperes for No. 10 copper; or 15 amperes for No.12 and 25 amperes for No. 10 aluminum and copper-clad aluminum after any correction factors for ambient temperature and number of conductors have been applied.

¹ Reprinted with permission from NEC 1999, NFPA 70, the National Electrical Code®, Copyright 1998, National Fire Protection Association, Quincy, MA 02269. This reprinted material is not the complete and official position of the National Fire Protection Association, on the referenced subject which is represented only by the standard in its entirety.

11.0 INSTALLATION DRAWINGS

Figure 11 Outline Drawing, 30-50 kVA UPS



DWG. NO. U3711001		DATE 2/1/02	 9650 JERONIMO RD. IRVINE, CALIFORNIA 92618
REV. NO. 2		ORDER NO.	
FILE NAME: _Ups_U3711001			
DRAWN BY V. CARMONA		TITLE OUTLINE DRAWING 30-50 KVA UPS MODULE NPPOWER	
CHK BY		SHEET NO 1 OF 1	
DES APVL		ECN NO	
		REF. DWG.	

Figure 12 Outline Drawing, 65-80 kVA UPS

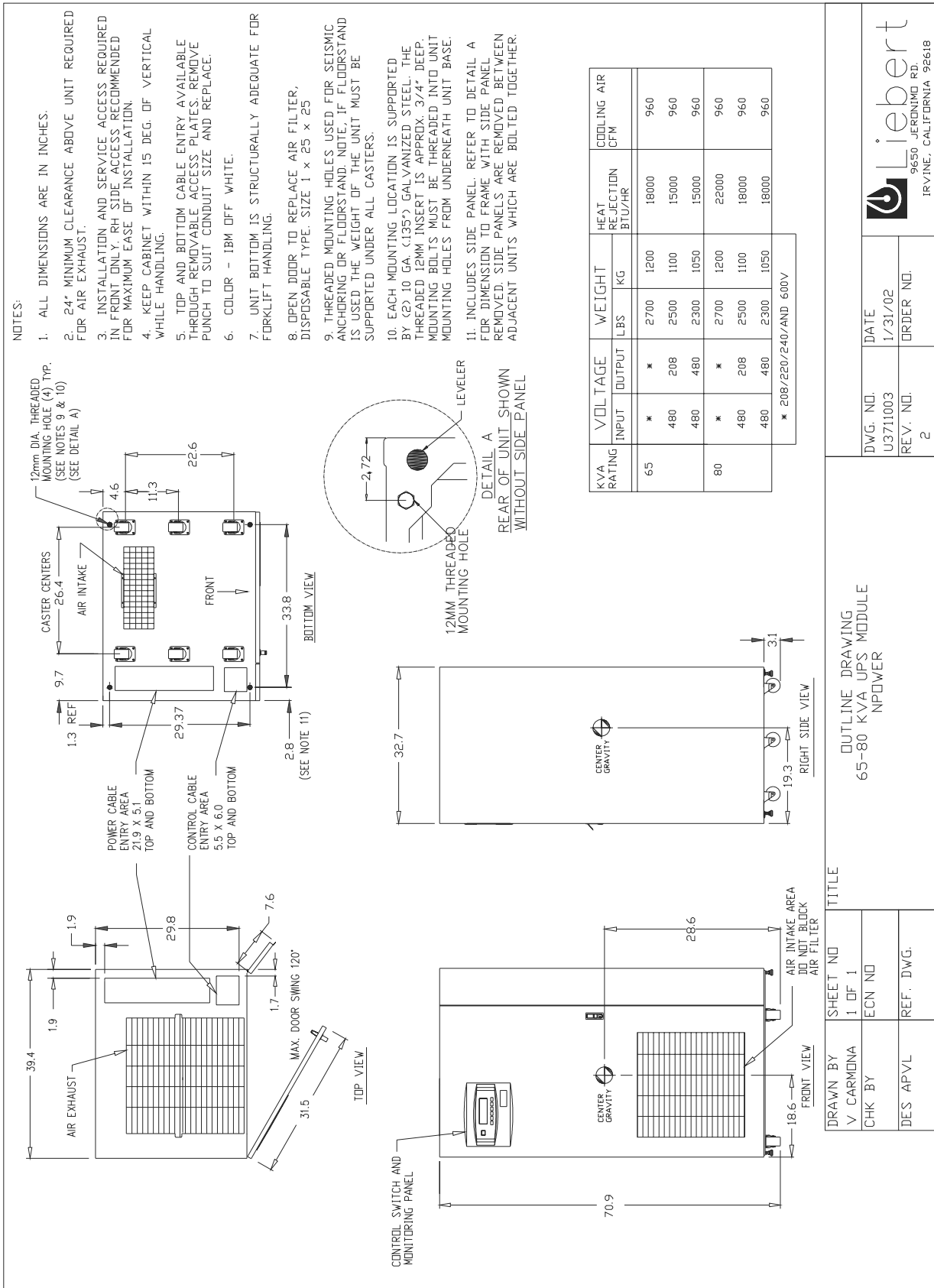
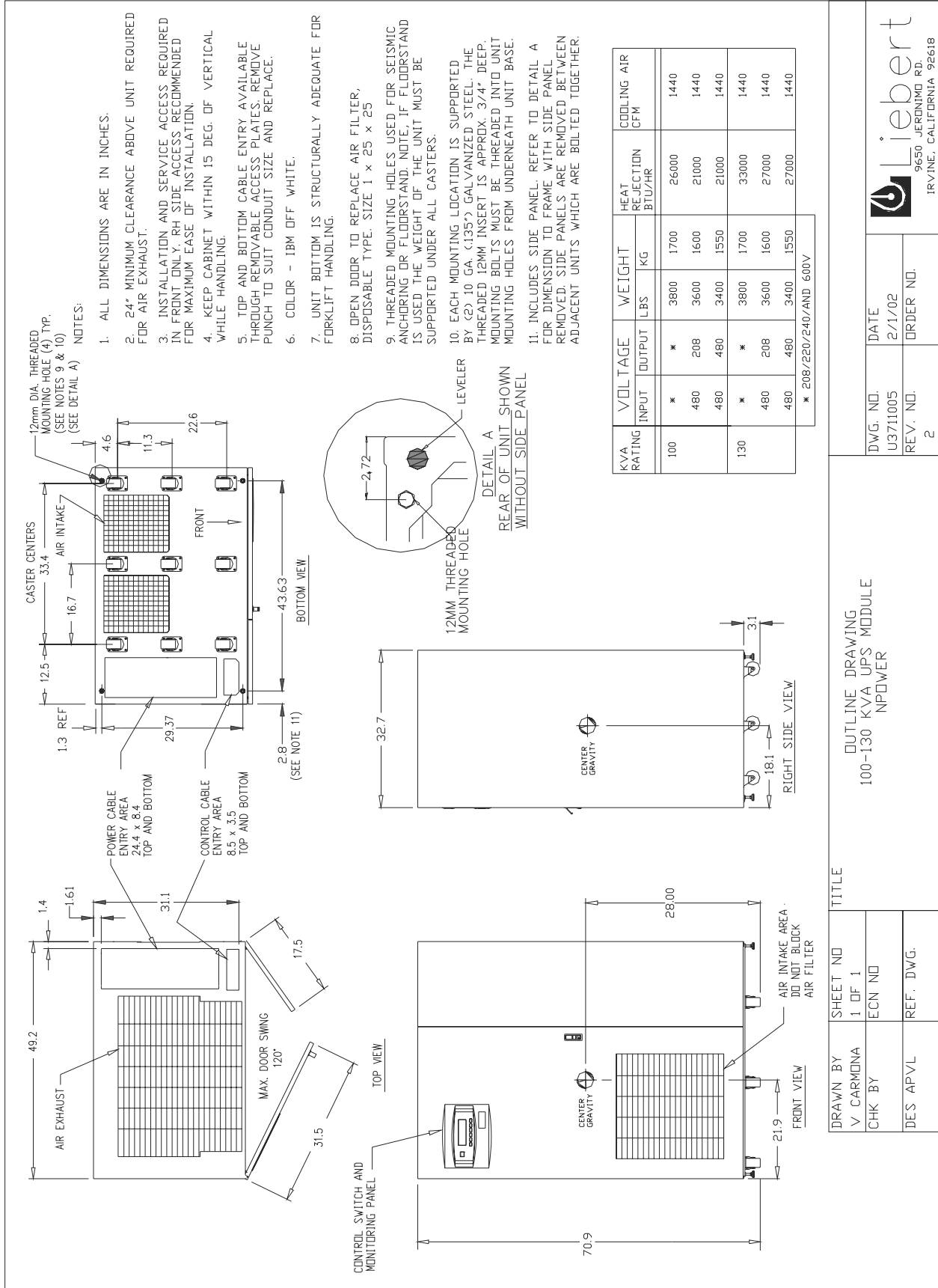


Figure 13 Outline Drawing, 100-130 kVA UPS



DWG. NO.	U3711005	DATE	2/1/02
REV. NO.	2	ORDER NO.	

FILE NAME: _UpsU3711005

OUTLINE DRAWING
100-130 KVA UPS MODULE
NPOWER

TITLE	SHEET NO	1 OF 1
DRAWN BY	CHK BY	ECN NO
V. CARMONA		
DES. APVL	REF. DWG.	

Figure 14 Outline Drawing, Battery Power Pack, 25-Inch Cabinet

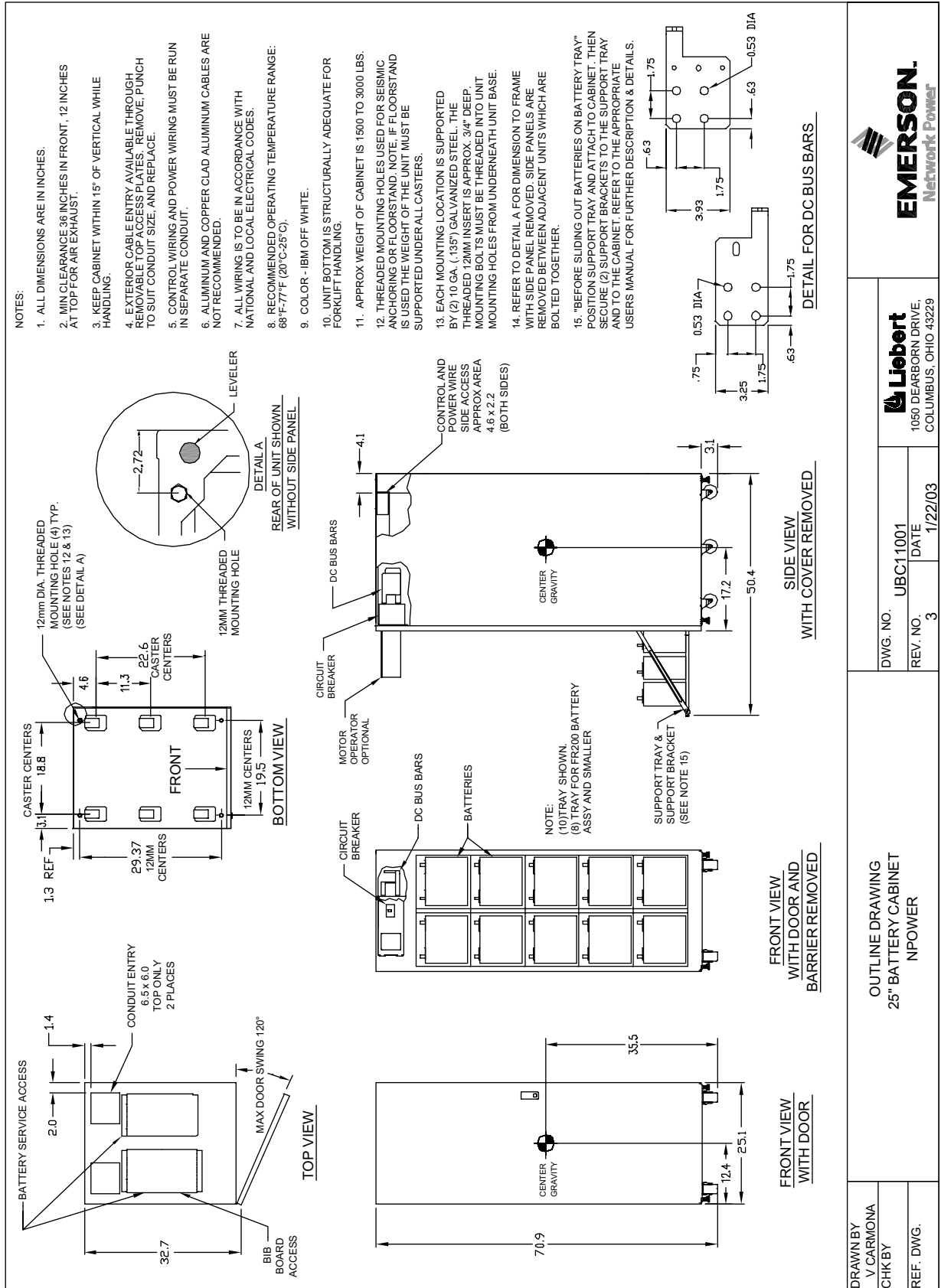


Figure 15 Outline Drawing, Battery Power Pack, 49-Inch Cabinet

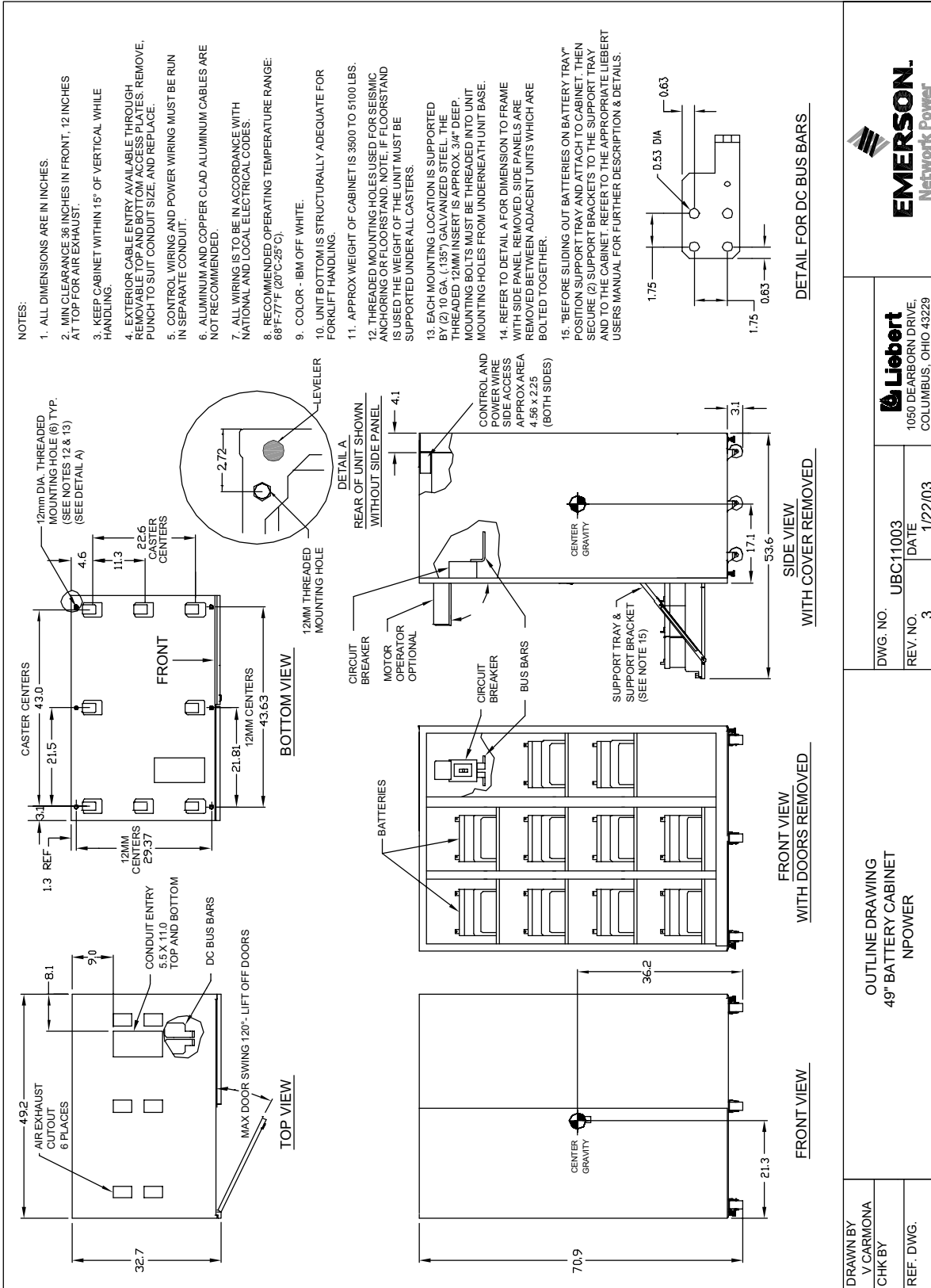


Figure 16 Outline Drawing, Maintenance Bypass Cabinet, "L" Configuration

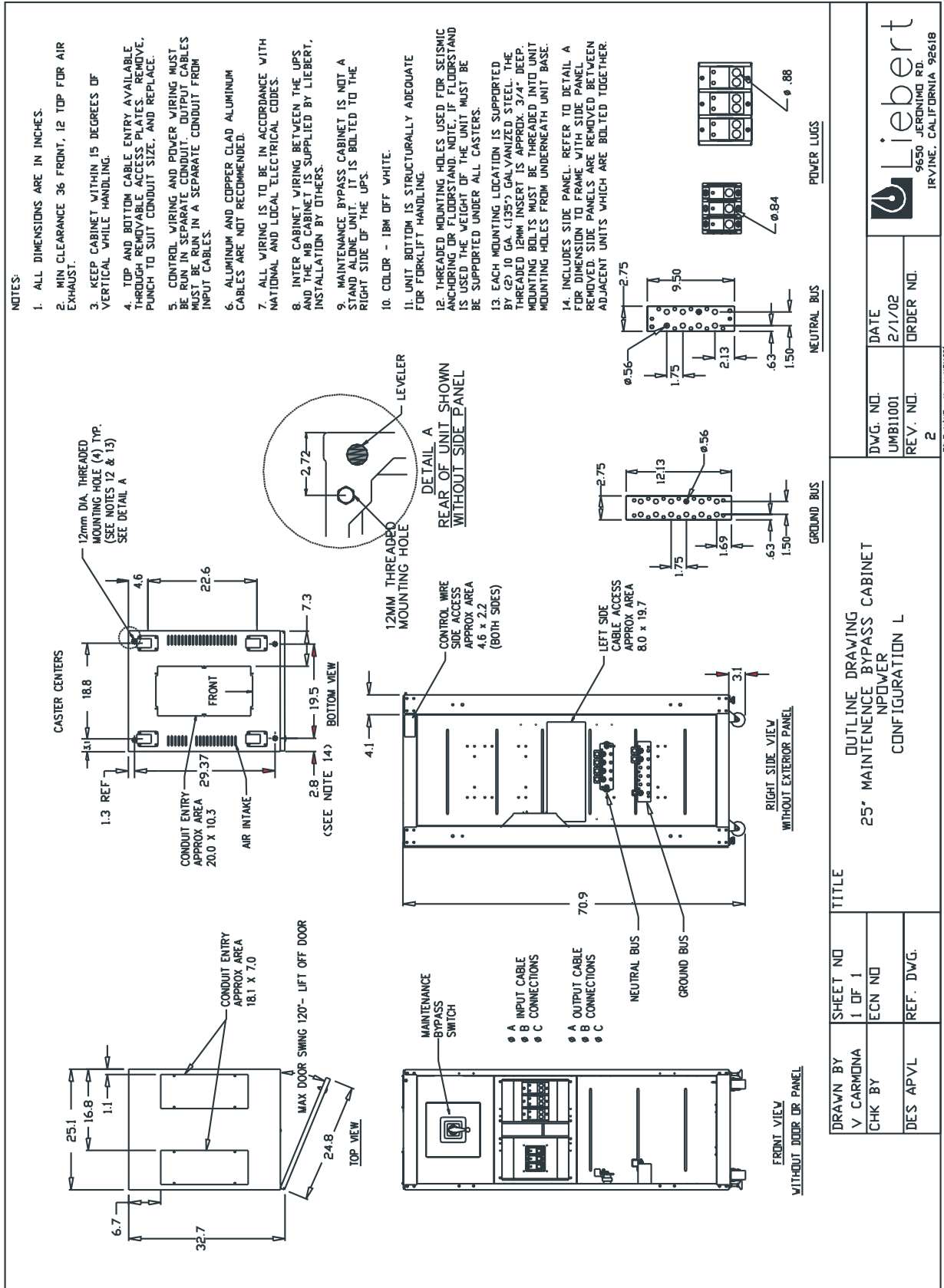


Figure 17 Outline Drawing, Maintenance Bypass Cabinet, "N" Configuration

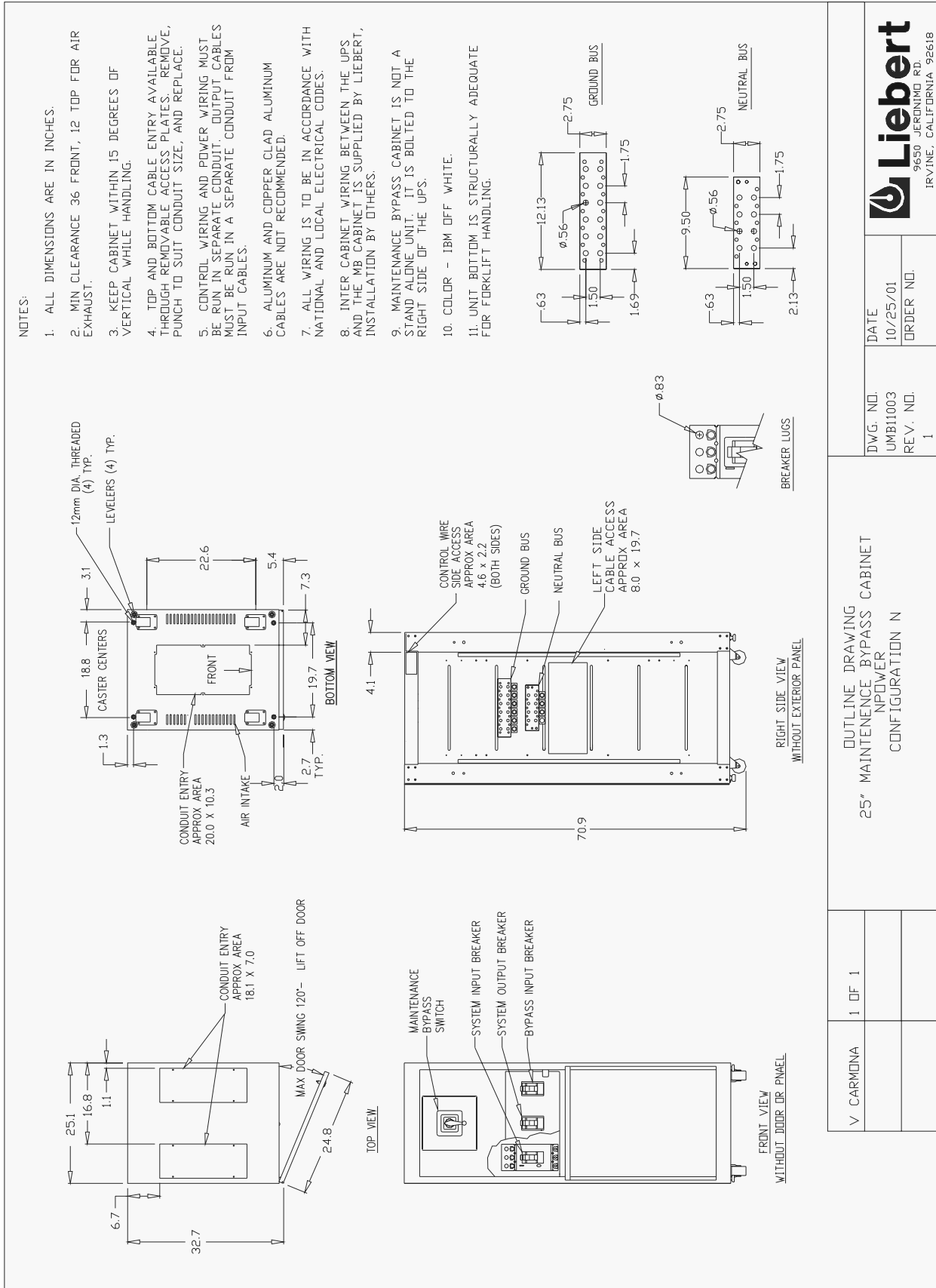


Figure 18 Outline Drawing, Maintenance Bypass Cabinet, "P" Configuration

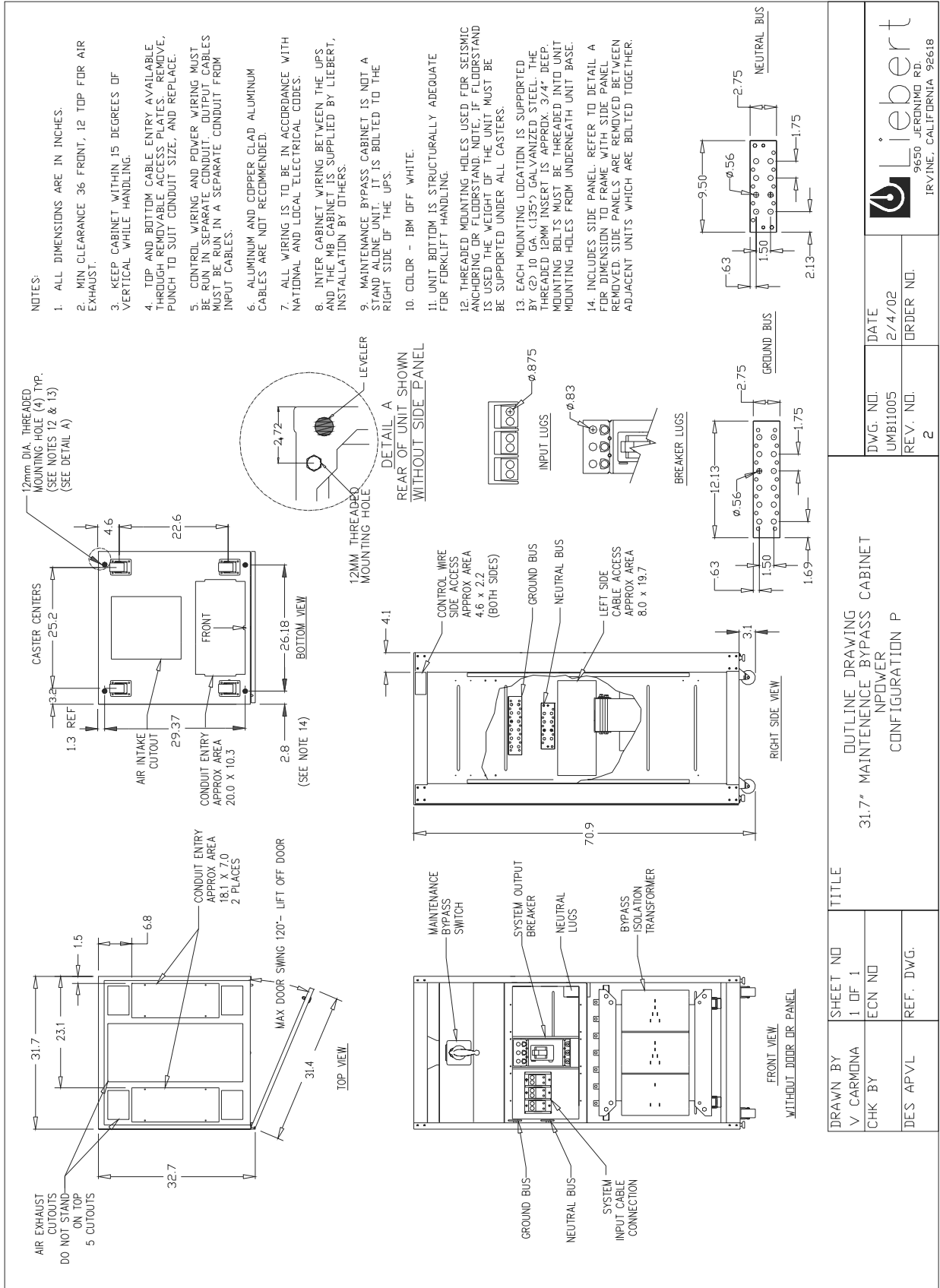
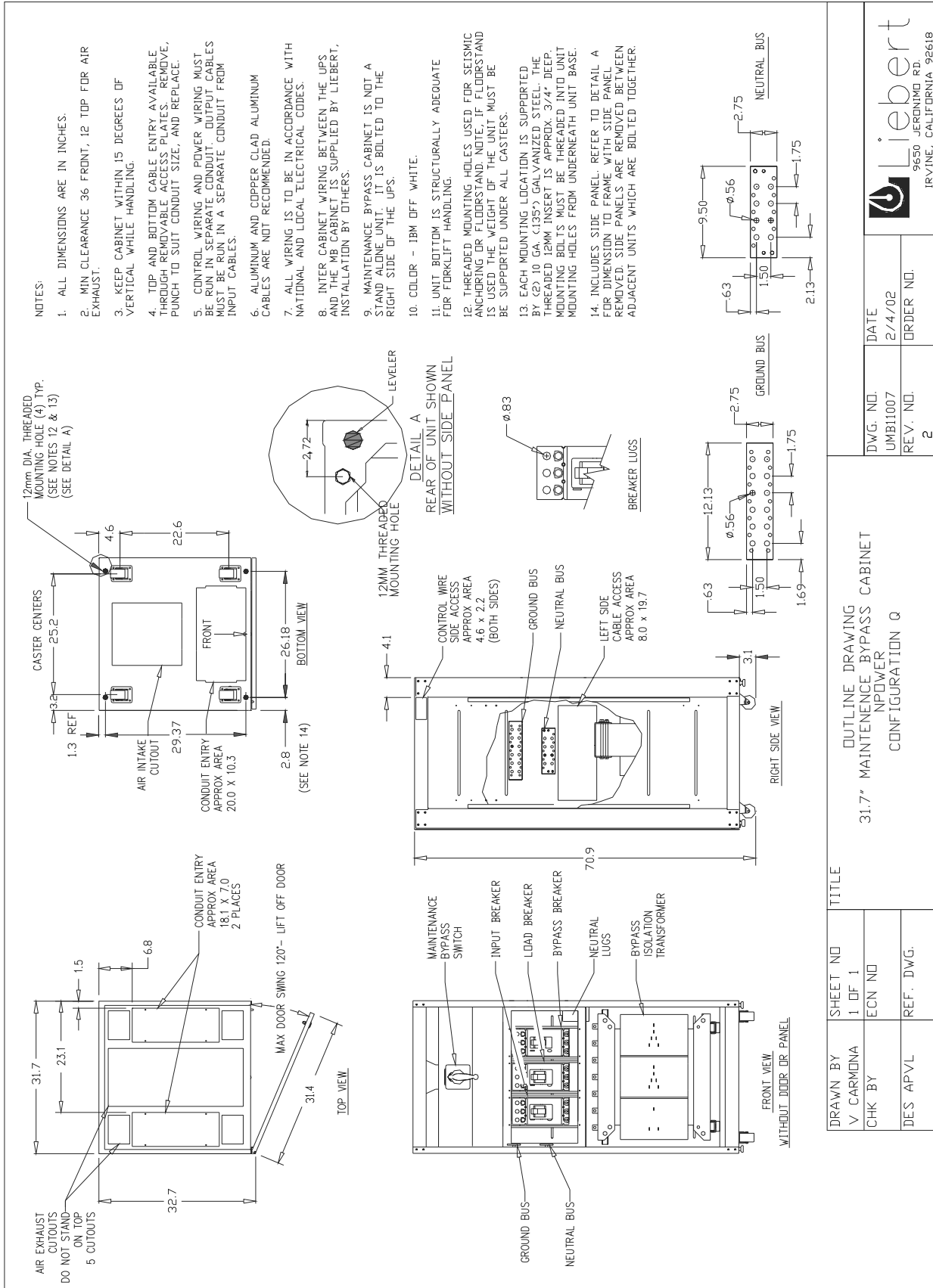
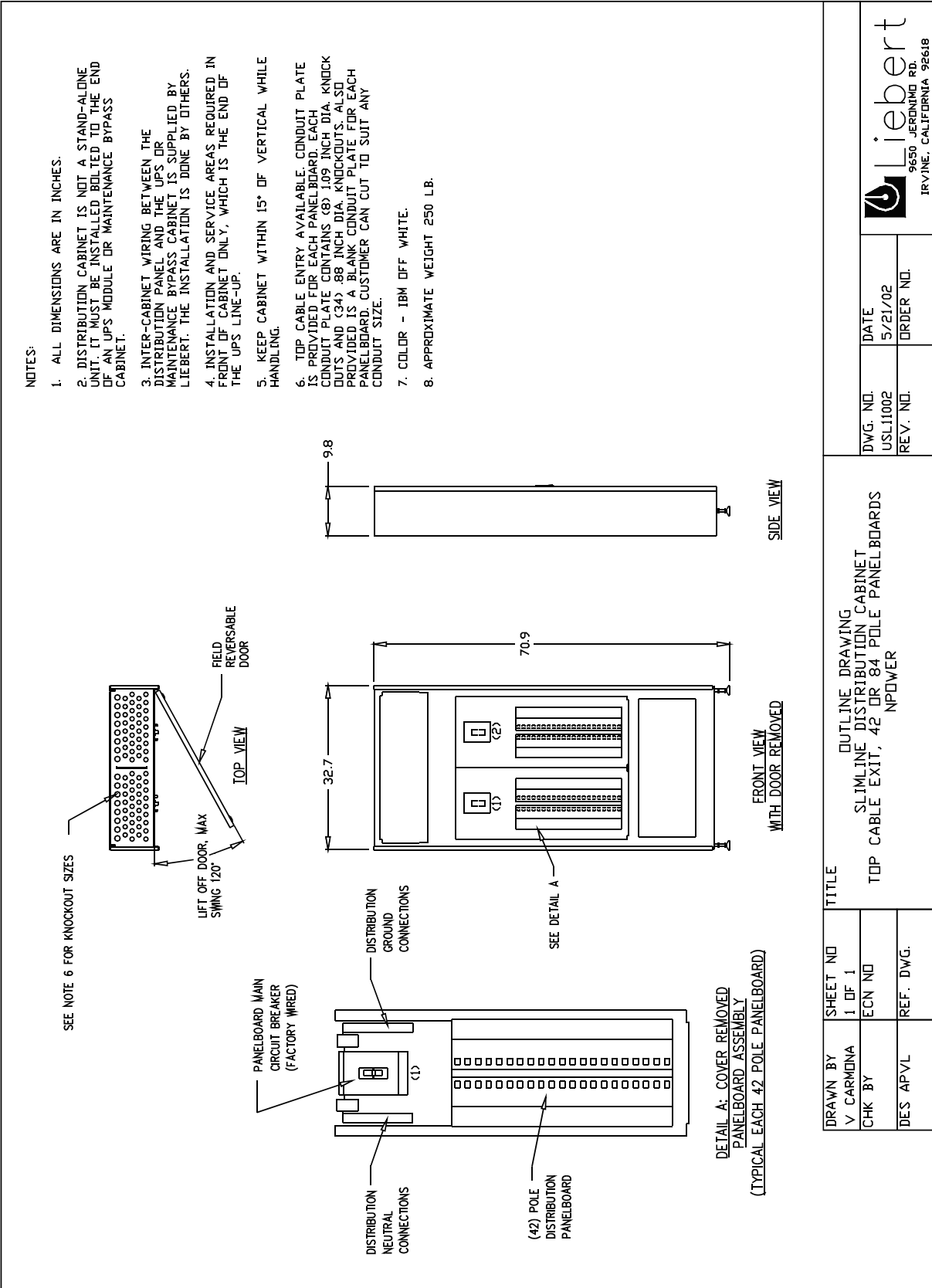



Figure 19 Outline Drawing, Maintenance Bypass Cabinet, "Q" Configuration



DRAWN BY V. CARMONA		SHEET NO 1 OF 1		TITLE 31.7" MAINTENANCE BYPASS CABINET NPOWER CONFIGURATION Q	
CHK BY		ECN NO		DWG. NO. UMB11007	
DES. APVL		REF. DWG.		DATE 2/4/02	
				ORDER NO.	
				REV. NO. 2	
				FILE NAME: _Mec_UMB11007	
				 9650 JERONIMO RD. IRVINE, CALIFORNIA 92618	

Figure 20 Outline Drawing, Slimline Distribution Cabinet, Top Cable Exit, Panelboards Only



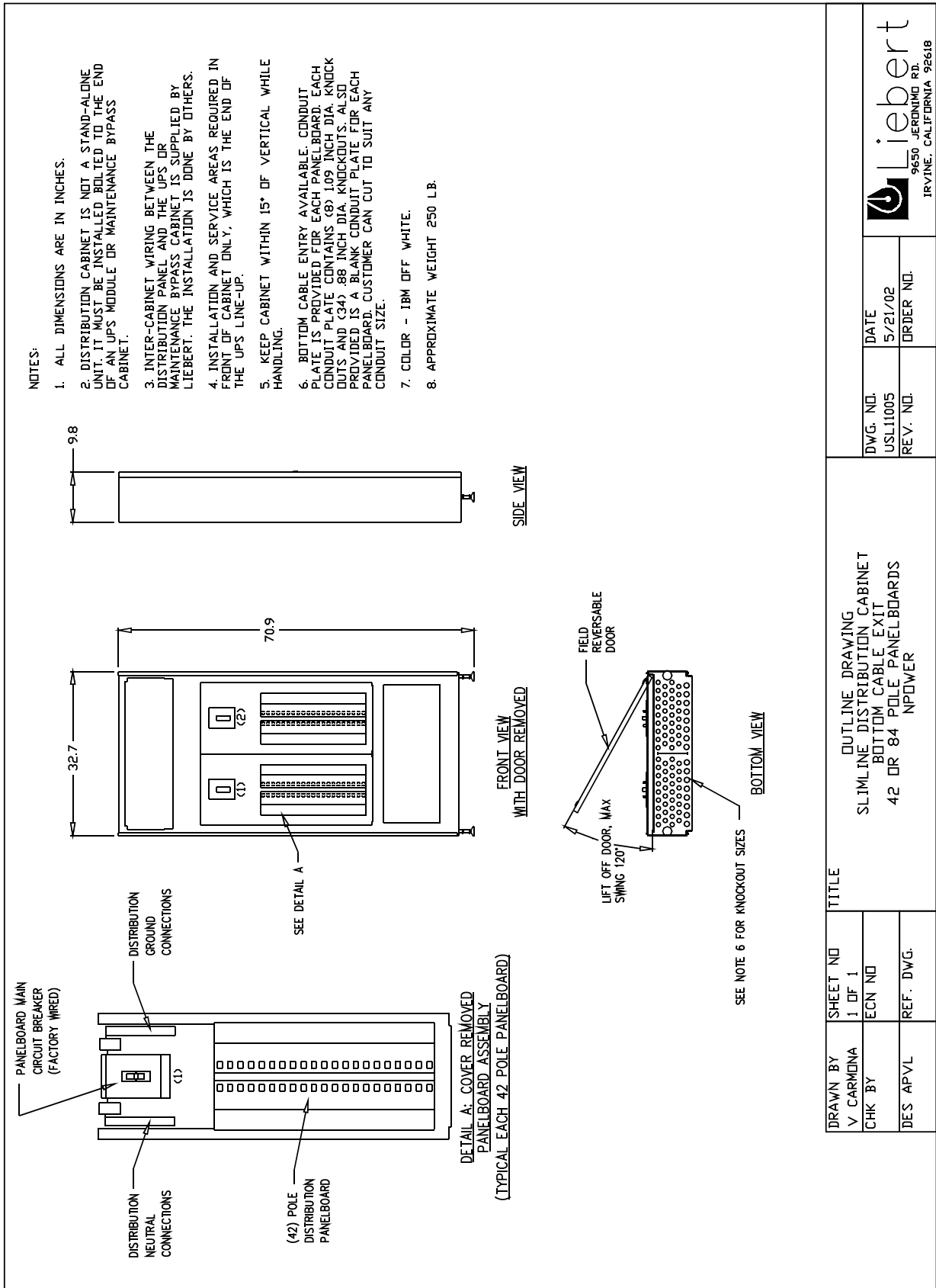
DWG. NO. USL11002	DATE 5/21/02	 Liebert 9650 JERONIMO RD. IRVINE, CALIFORNIA 92618
REV. NO.	ORDER NO.	

FILE NAME: Distres_Sm-USL1002

TITLE OUTLINE DRAWING SLIMLINE DISTRIBUTION CABINET TOP CABLE EXIT, 42 OR 84 POLE PANELBOARDS NPOWER	
--	--

DRAWN BY V. CARMONA	SHEET NO 1 OF 1
CHK BY	ECN NO
DES. APVL	REF. DWG.

Figure 21 Outline Drawing, Slimline Distribution Cabinet, Bottom Cable Exit, Panelboards Only



DRAWN BY		SHEET NO	
V. CARMONA		1 OF 1	
CHK BY		ECN NO	
DES APVL		REF. DWG.	

TITLE
 OUTLINE DRAWING
 SLIMLINE DISTRIBUTION CABINET
 BOTTOM CABLE EXIT
 42 OR 84 POLE PANELBOARDS
 NPOWER

DWG. NO.	DATE
USL11005	5/21/02
REV. NO.	ORDER NO.



FILE NAME: Outlines_SlipUSL11005

Figure 22 Outline Drawing, Slimline Distribution Cabinet, with Panelboard and Subfeed Breakers

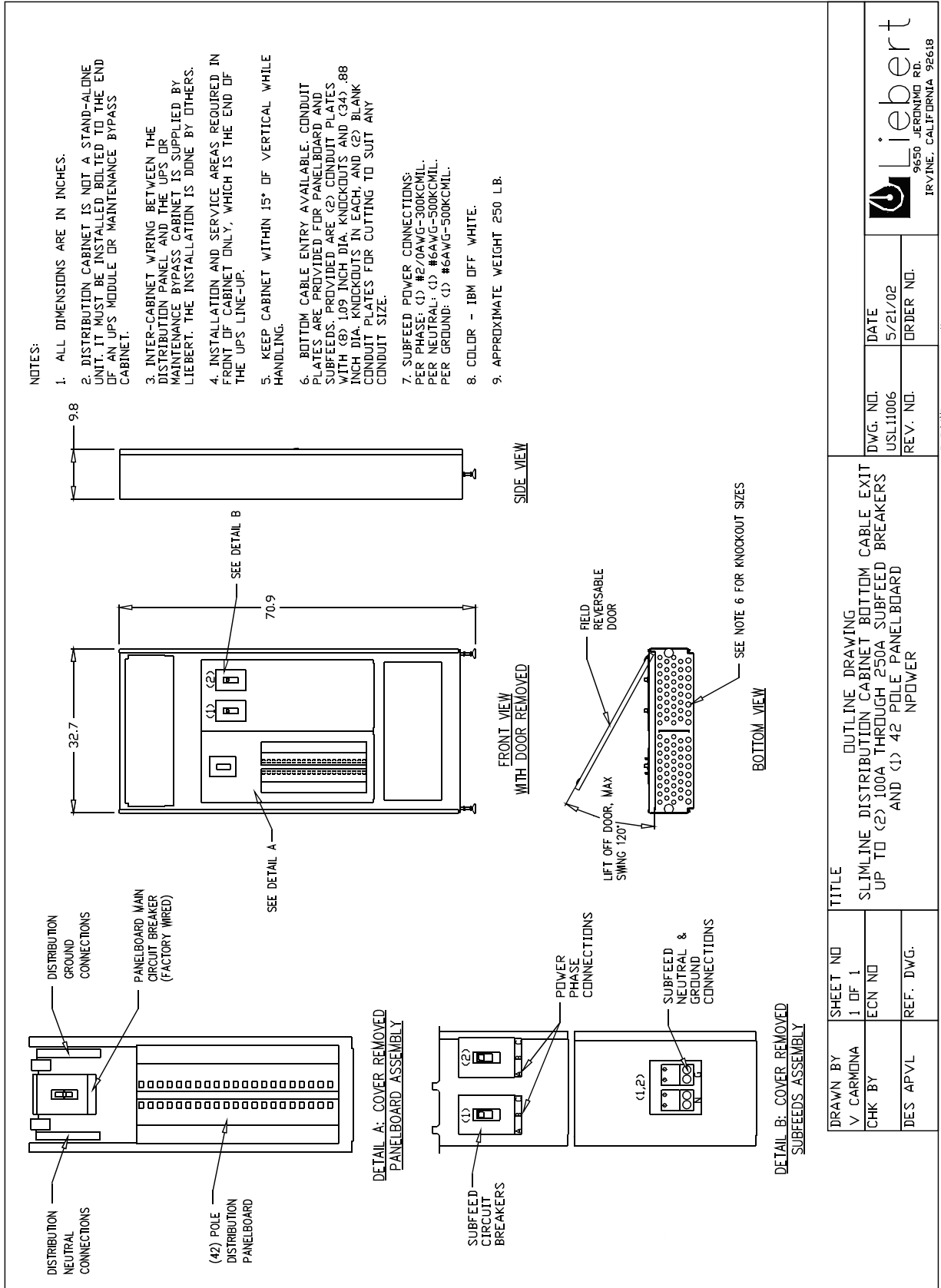


Figure 23 Outline Drawing, Slimline Distribution Cabinet, with 100-250A Subfeed Breakers Only

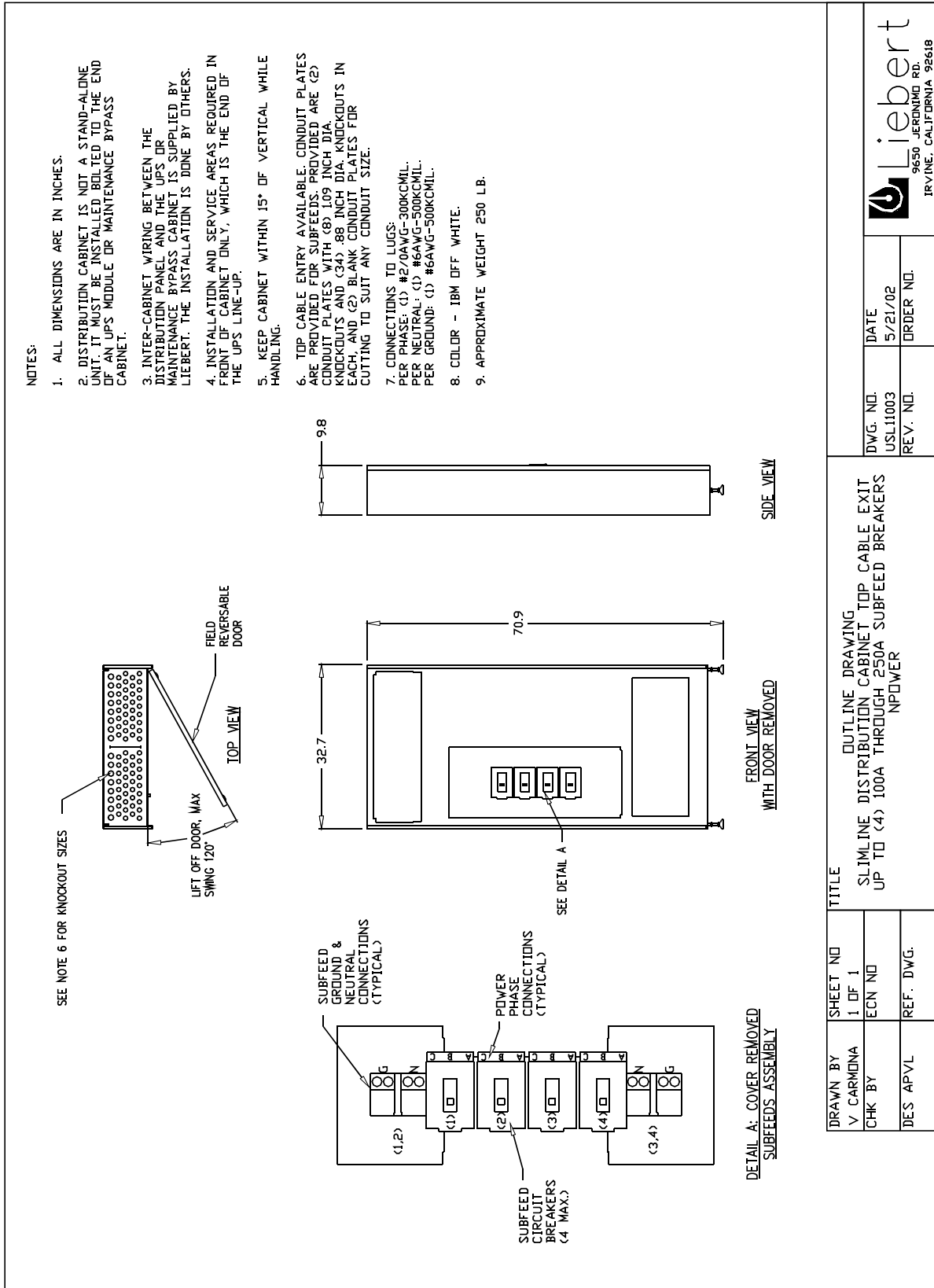


Figure 24 Outline Drawing, Slimline Distribution Cabinet, with 300-400A Subfeed Breakers Only

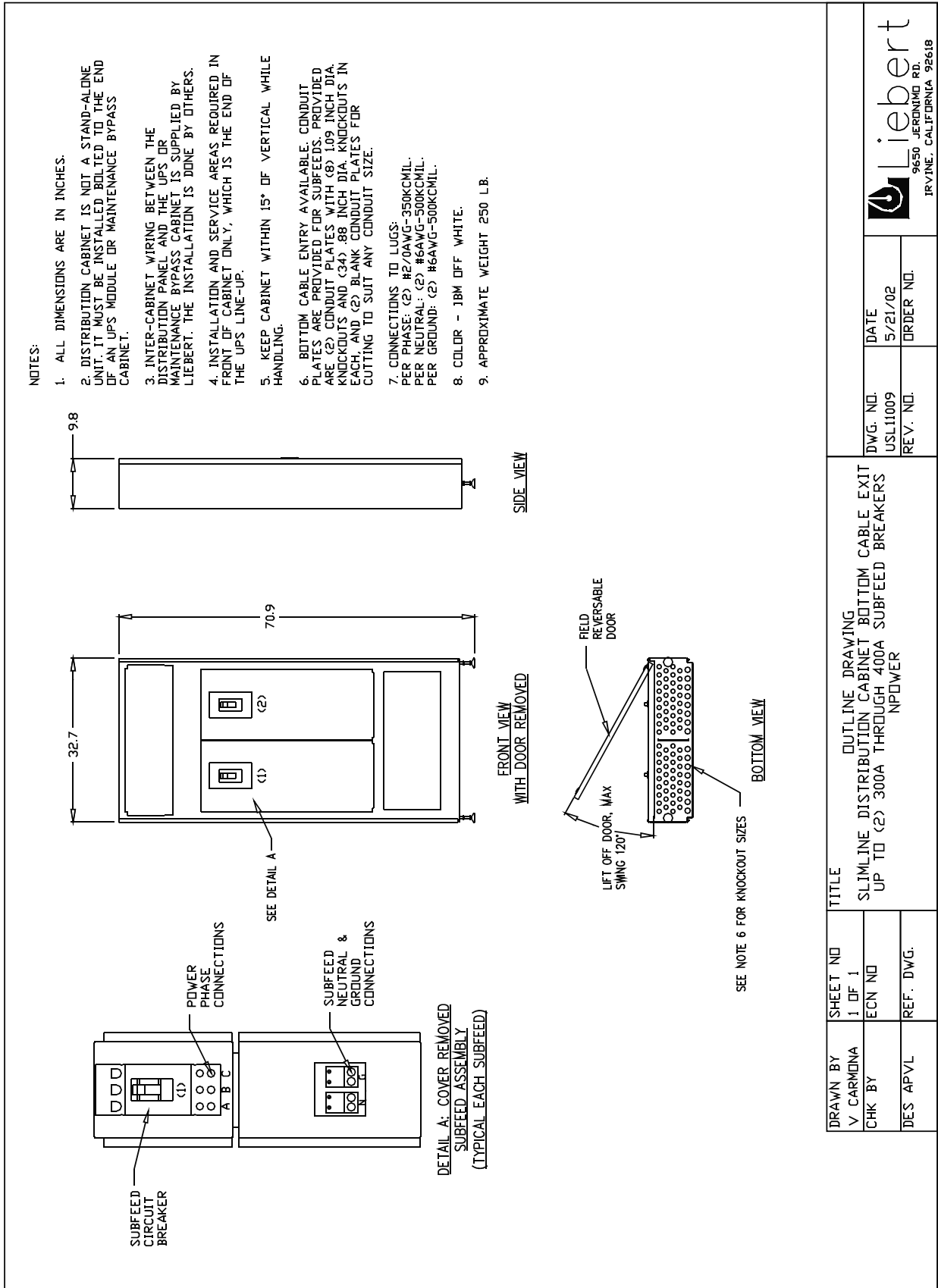


Figure 25 Specifications Table, 1+1 Paralleling Panelboard Configuration "N"

1+1 UPS RATING		"N" TYPE 3-BREAKER PANELBOARD					DRAWING NUMBER	
KVA	OUTPUT VOLTAGE	CIRCUIT BREAKER AMPS	PANELBOARD	CIRCUIT BREAKER	INTERRUPT (AIC)	WEIGHT (LBS)		PANEL SIZE
30	208V	125	I-LINE	SQ-D 'QD'	22	200	B	U3711009
	220V	100	NF	SQ-D 'EDB'	25	100	A	U3711008
	240V	100	NF	SQ-D 'EDB'	25	100	A	U3711008
	480V	50	NF	SQ-D 'EDB'	18	100	A	U3711008
	600V	50	I-LINE	SQ-D 'FA'	14	200	B	U3711009
40	208V	150	I-LINE	SQ-D 'QD'	22	200	B	U3711009
	220V	150	I-LINE	SQ-D 'QD'	22	200	B	U3711009
	240V	125	I-LINE	SQ-D 'QD'	22	200	B	U3711009
	480V	60	NF	SQ-D 'EDB'	18	100	A	U3711008
	600V	50	I-LINE	SQ-D 'FA'	14	200	B	U3711009
50	208V	175	I-LINE	SQ-D 'QD'	22	200	B	U3711009
	220V	175	I-LINE	SQ-D 'QD'	22	200	B	U3711009
	240V	150	I-LINE	SQ-D 'QD'	22	200	B	U3711009
	480V	80	NF	SQ-D 'EDB'	18	100	A	U3711008
	600V	60	NF	SQ-D 'FA'	14	200	B	U3711009
65	208V	225	I-LINE	SQ-D 'QD'	22	200	B	U3711009
	220V	225	I-LINE	SQ-D 'QD'	22	200	B	U3711009
	240V	200	I-LINE	SQ-D 'QD'	22	200	B	U3711009
	480V	100	NF	SQ-D 'EDB'	18	100	A	U3711008
	600V	80	I-LINE	SQ-D 'FA'	14	200	B	U3711009
80	208V	300	I-LINE	SQ-D 'LA'	25	400	C	U3711010
	220V	300	I-LINE	SQ-D 'LA'	25	400	C	U3711010
	240V	250	I-LINE	SQ-D 'KA'	25	250	B	U3711009
	480V	125	I-LINE	SQ-D 'KA'	25	200	B	U3711009
	600V	100	I-LINE	SQ-D 'FA'	14	200	B	U3711009
100	208V	350	I-LINE	SQ-D 'LA'	25	400	C	U3711010
	220V	350	I-LINE	SQ-D 'LA'	25	400	C	U3711010
	240V	300	I-LINE	SQ-D 'LA'	25	400	C	U3711010
	480V	150	I-LINE	SQ-D 'KA'	25	200	B	U3711009
	600V	125	I-LINE	SQ-D 'KA'	22	200	B	U3711009
130	208V	450	I-LINE	SQ-D 'LC'	42	450	C	U3711010
	220V	450	I-LINE	SQ-D 'LC'	42	450	C	U3711010
	240V	400	I-LINE	SQ-D 'LA'	25	400	C	U3711010
	480V	200	I-LINE	SQ-D 'KA'	25	200	B	U3711009
	600V	175	I-LINE	SQ-D 'KA'	22	200	B	U3711009



Liebert
 1050 DEARBORN DRIVE,
 COLUMBUS, OHIO 43229

DWG. NO. U3711007
 REV. NO. DATE 6/17/03
 FILE NAME: \\APL\POWER\DRAWINGS\OUTLINE\1+1SPC\U3711007(C)

OUTLINE DRAWING
 NPOWER 1+1
 SYSTEM PARALLELING PANELBOARD
 CONFIGURATION "N", COMMON INFORMATION

DRAWN BY M MIERSEN
 CHK BY
 REF. DWG.

Figure 26 Outline Drawing, 1+1 Paralleling Panelboard, Configuration "N," Size "A"

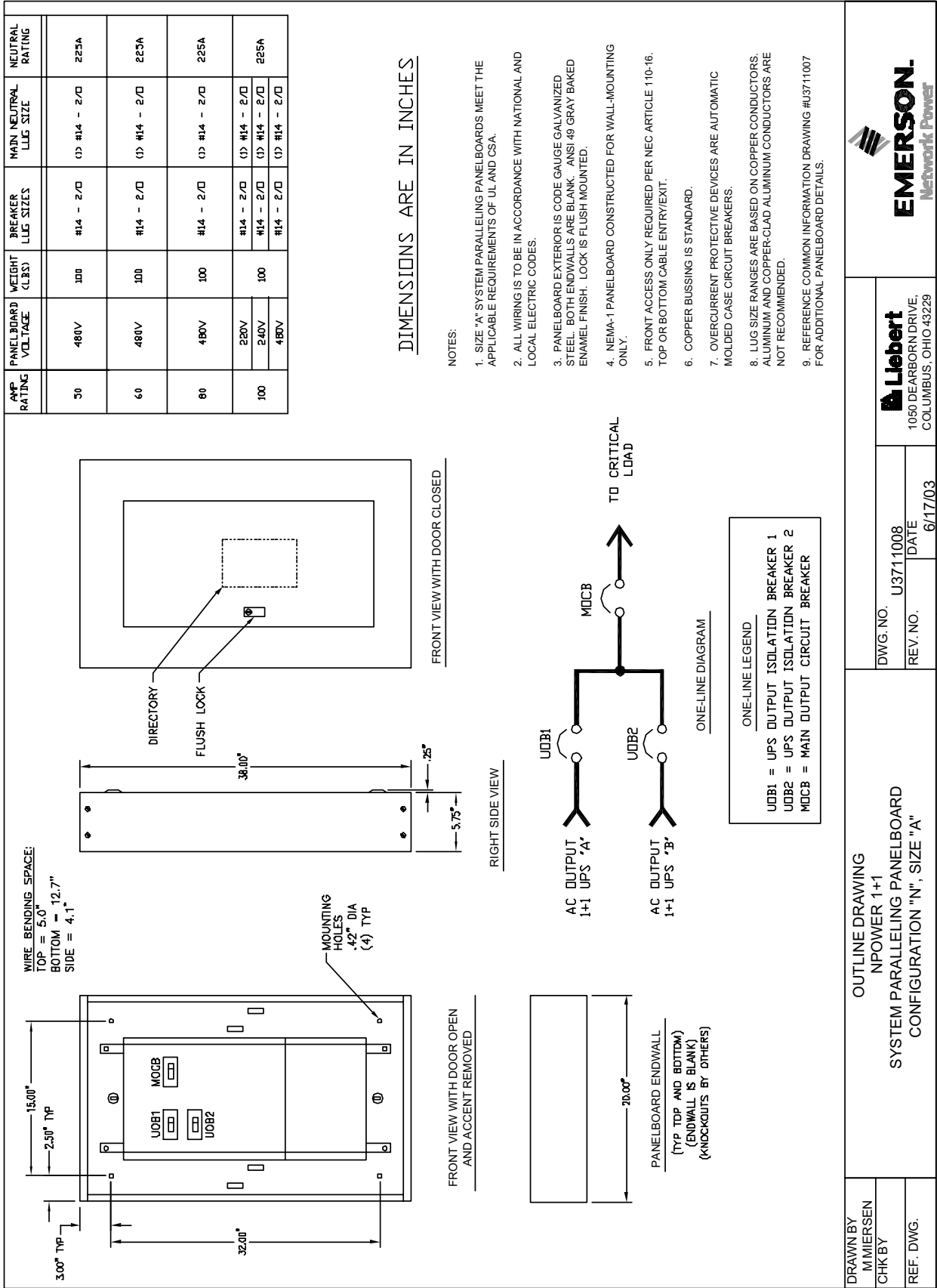
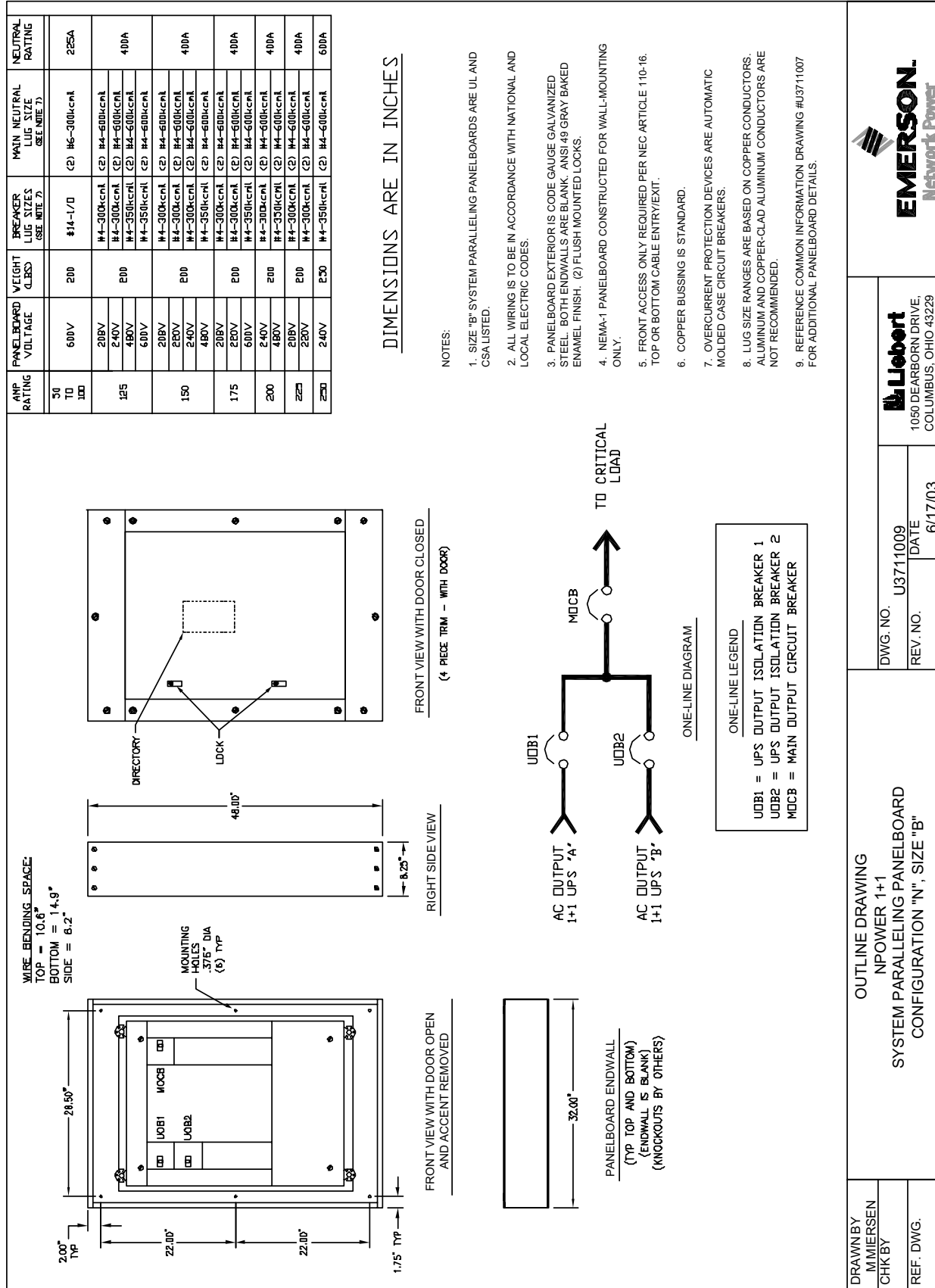


Figure 27 Outline Drawing, 1+1 Paralleling Panelboard, Configuration "N," Size "B"



DIMENSIONS ARE IN INCHES

- NOTES:
1. SIZE "B" SYSTEM PARALLELING PANELBOARDS ARE UL AND CSA LISTED.
 2. ALL WIRING IS TO BE IN ACCORDANCE WITH NATIONAL AND LOCAL ELECTRIC CODES.
 3. PANELBOARD EXTERIOR IS CODE GAUGE GALVANIZED STEEL. BOTH ENDWALLS ARE BLANK. ANSI #9 GRAY BAKED ENAMEL FINISH. (2) FLUSH MOUNTED LOCKS.
 4. NEMA-1 PANELBOARD CONSTRUCTED FOR WALL-MOUNTING ONLY.
 5. FRONT ACCESS ONLY REQUIRED PER NEC ARTICLE 110-16. TOP OR BOTTOM CABLE ENTRY/EXIT.
 6. COPPER BUSSING IS STANDARD.
 7. OVERCURRENT PROTECTION DEVICES ARE AUTOMATIC MOLDED CASE CIRCUIT BREAKERS.
 8. LUG SIZE RANGES ARE BASED ON COPPER CONDUCTORS. ALUMINUM AND COPPER-CLAD ALUMINUM CONDUCTORS ARE NOT RECOMMENDED.
 9. REFERENCE COMMON INFORMATION DRAWING #U3711007 FOR ADDITIONAL PANELBOARD DETAILS.

DRAWN BY MMIERSEN CHK BY	OUTLINE DRAWING NPOWER 1+1 SYSTEM PARALLELING PANELBOARD CONFIGURATION "N", SIZE "B"		DWG. NO. U3711009	REV. NO. DATE 6/17/03	FILE NAME: \APPL\POWER\DRAWINGS\OUTLINES\1+1SPFCU3711009(C)
	REF. DWG.	EMERSON Network Power			

Figure 28 Outline Drawing, 1+1 Paralleling Panelboard, Configuration "N," Size "C"

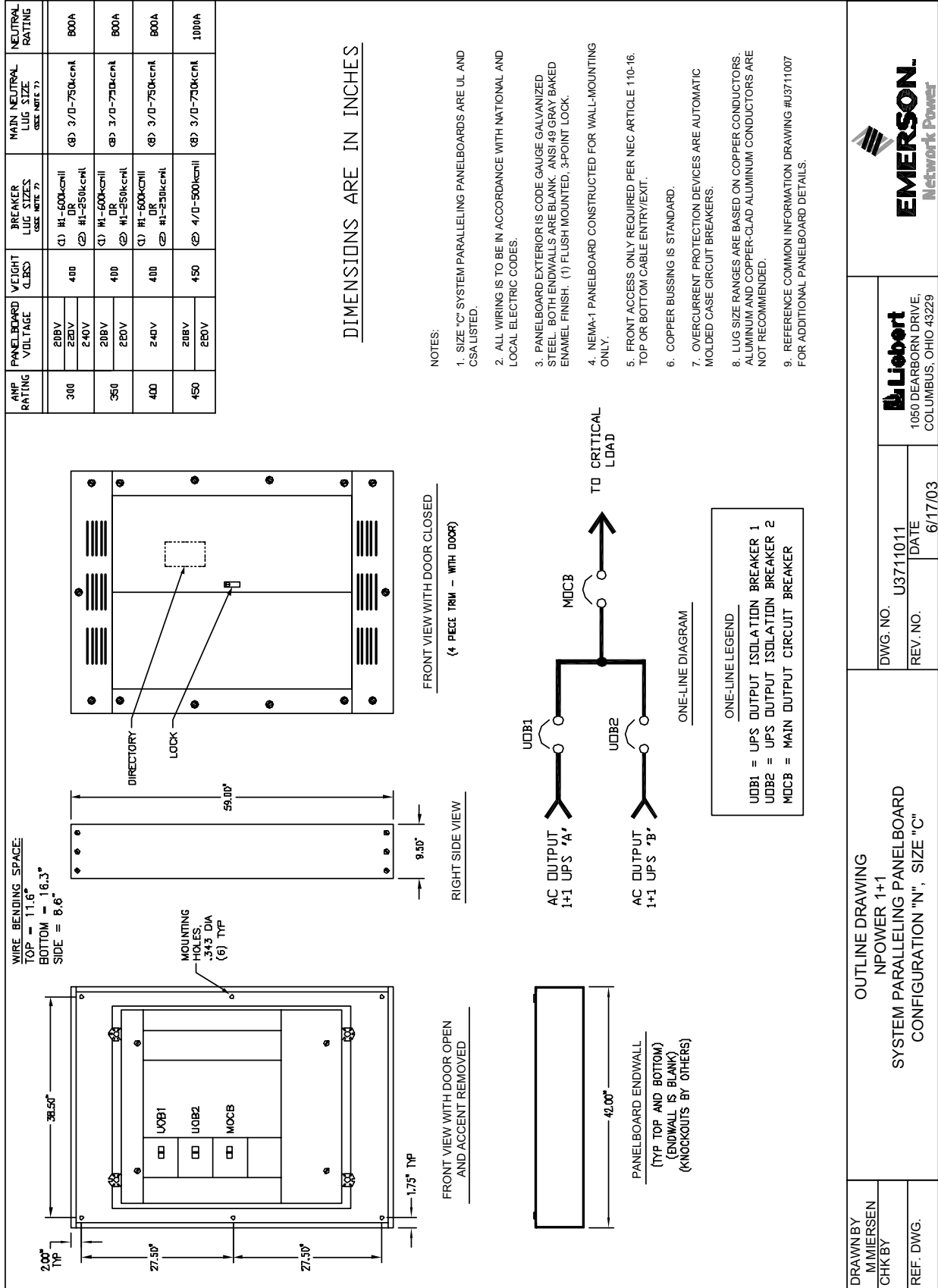
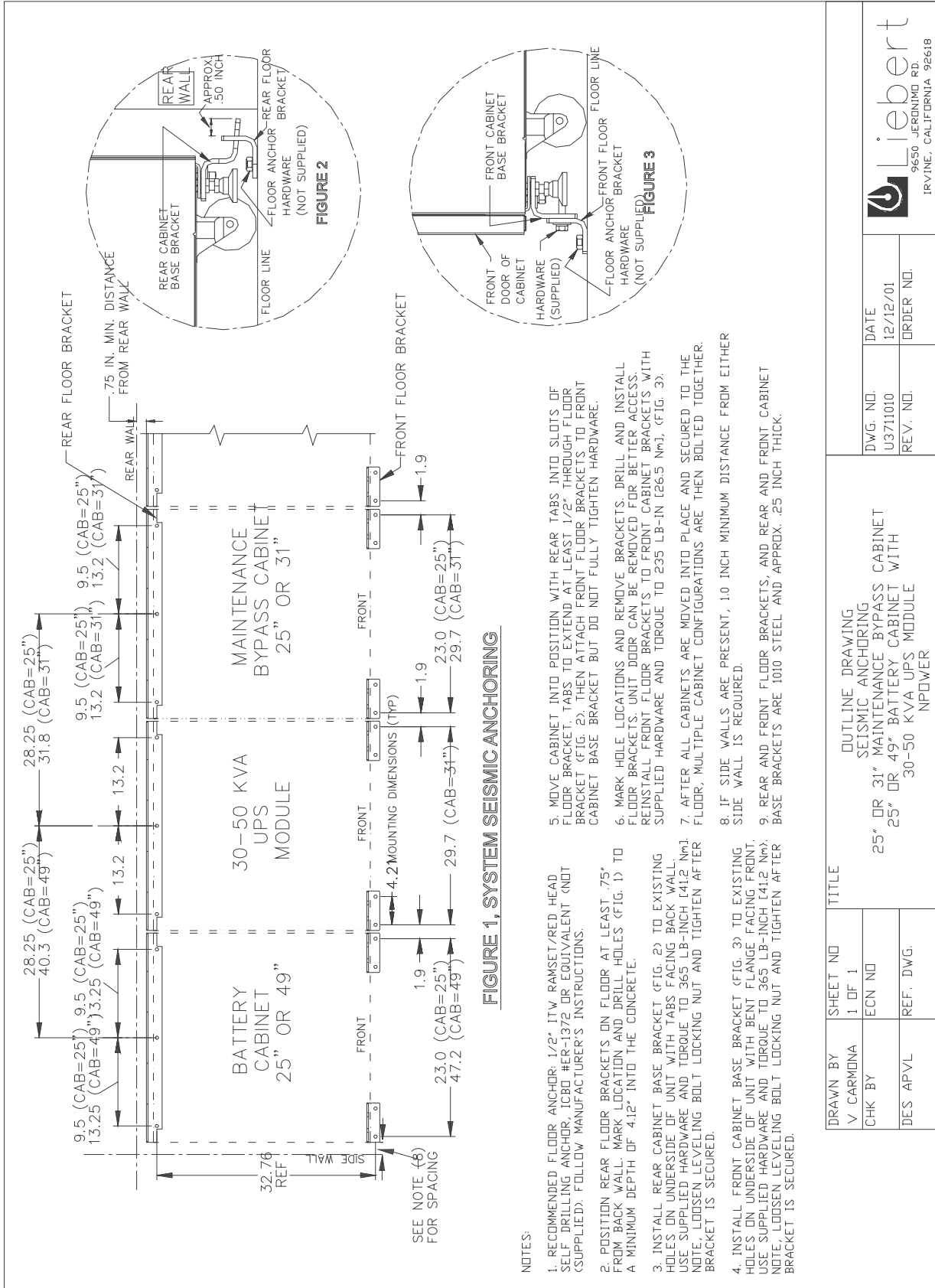


Figure 29 Outline Drawing, Seismic Anchoring, 30-50 kVA UPS



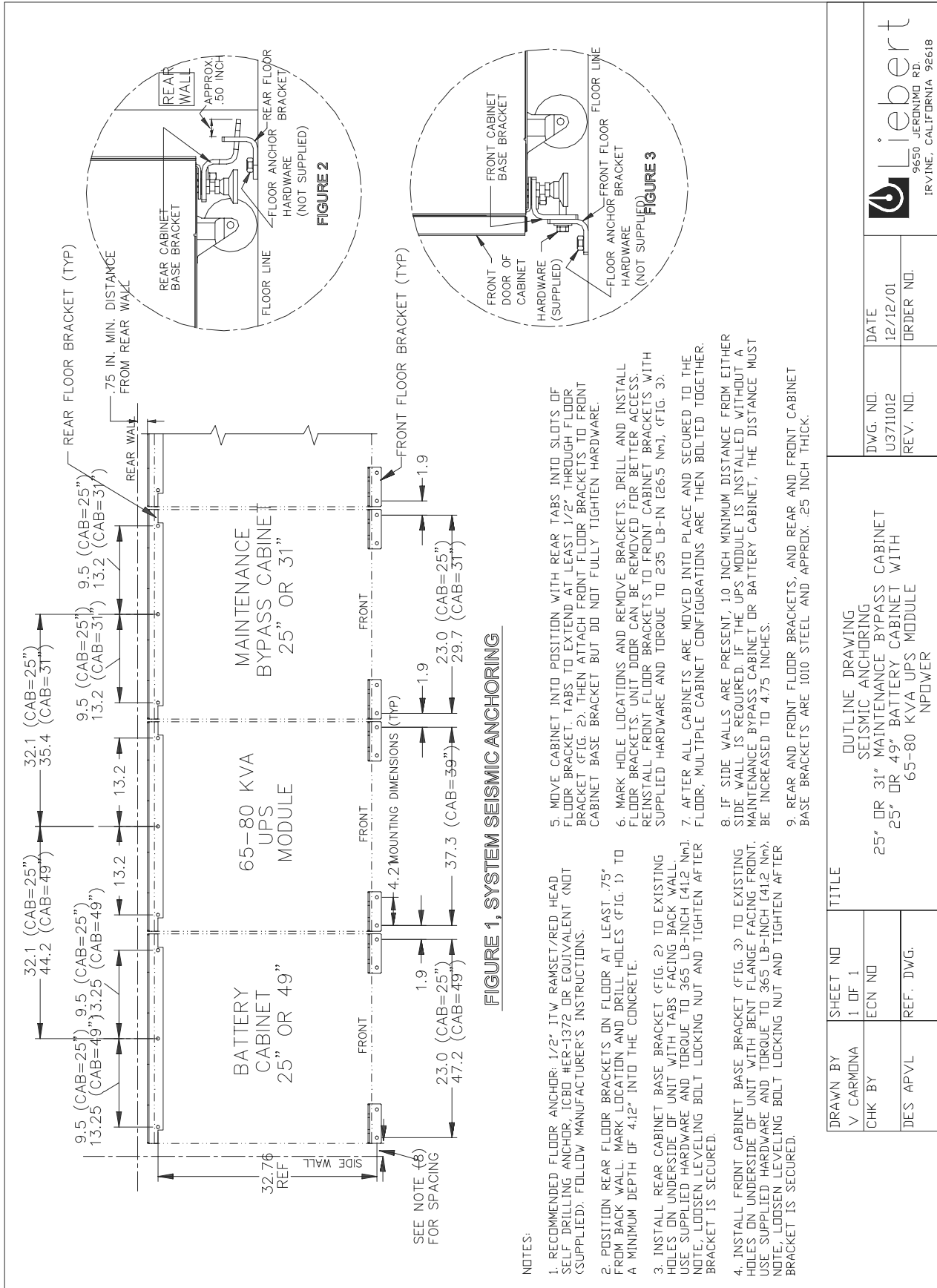
DRAWN BY V. CARMONA	SHEET NO 1 OF 1	TITLE OUTLINE DRAWING SEISMIC ANCHORING
CHK BY	ECN NO	25" OR 31" MAINTENANCE BYPASS CABINET 25" OR 49" BATTERY CABINET WITH 30-50 KVA UPS MODULE NPOWVER
DES APVL	REF. DWG.	

DWG. NO. U3711010	DATE 12/12/01
REV. NO.	ORDER NO.



FILE NAME: S065mc U3711000

Figure 30 Outline Drawing, Seismic Anchoring, 65-80 kVA UPS

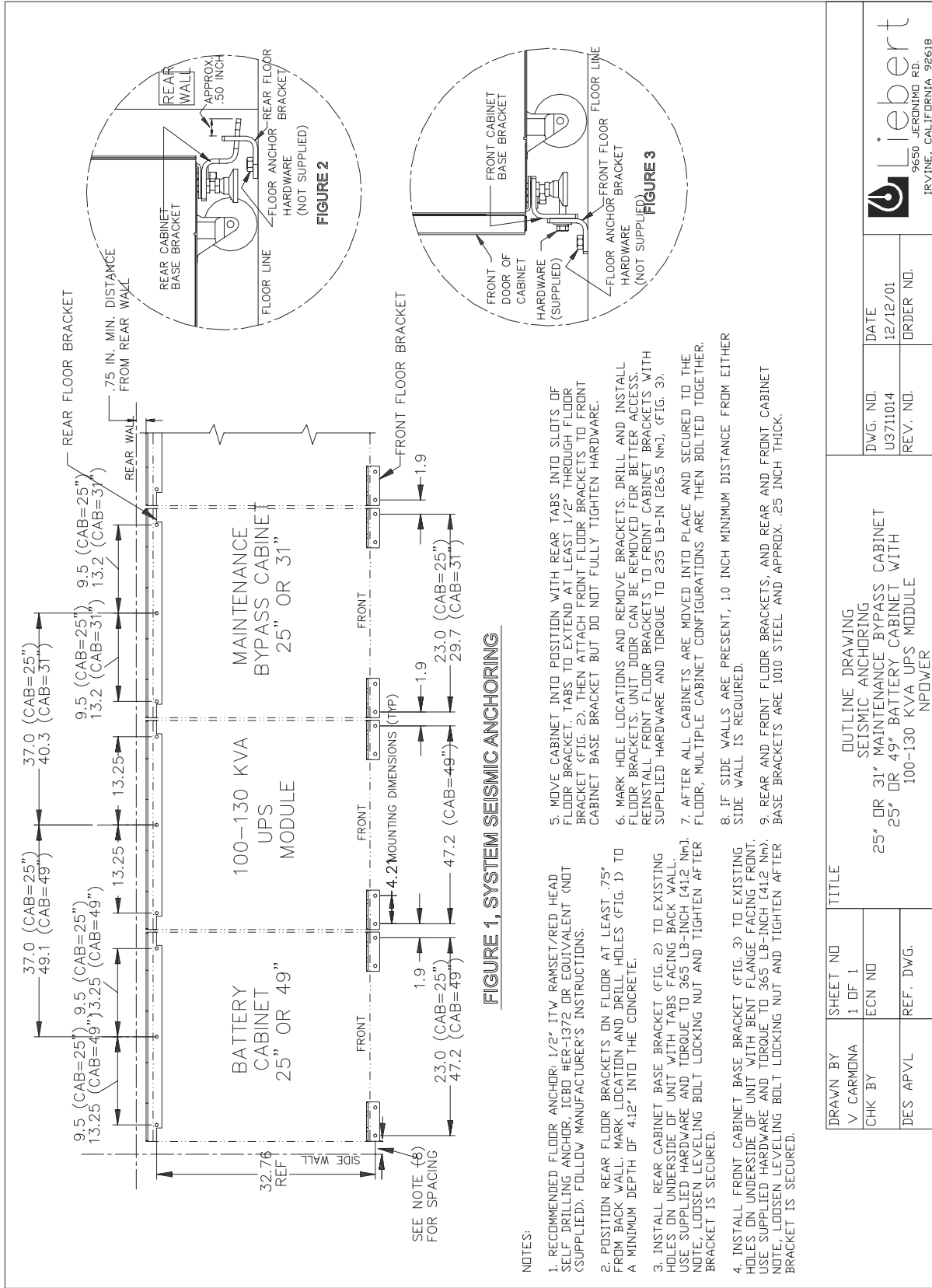


DRAWN BY V. CARMONA		SHEET NO 1 OF 1		TITLE OUTLINE DRAWING SEISMIC ANCHORING	
CHK BY		ECN NO		25" OR 31" MAINTENANCE BYPASS CABINET 25" OR 49" BATTERY CABINET WITH 65-80 KVA UPS MODULE NPOWER	
DES APVL		REF. DWG.		DWG. NO. U3711012	
				DATE 12/12/01	
				ORDER NO.	



FILE NAME: Seismic_U3711012

Figure 31 Outline Drawing, Seismic Anchoring, 100-130 kVA UPS



DRAWN BY V. CARMONA		SHEET NO 1 OF 1		TITLE OUTLINE DRAWING SEISMIC ANCHORING	
CHK BY		ECN NO		25" OR 31" MAINTENANCE BYPASS CABINET 100-130 KVA UPS MODULE POWER	
DES APVL		REF. DWG.		DWG. NO. U3711014	DATE 12/12/01
				REV. NO.	ORDER NO.

FILE NAME: S36HC-U371014



Figure 32 Outline Drawing, Remote Battery Breaker 30 - 130 kVA

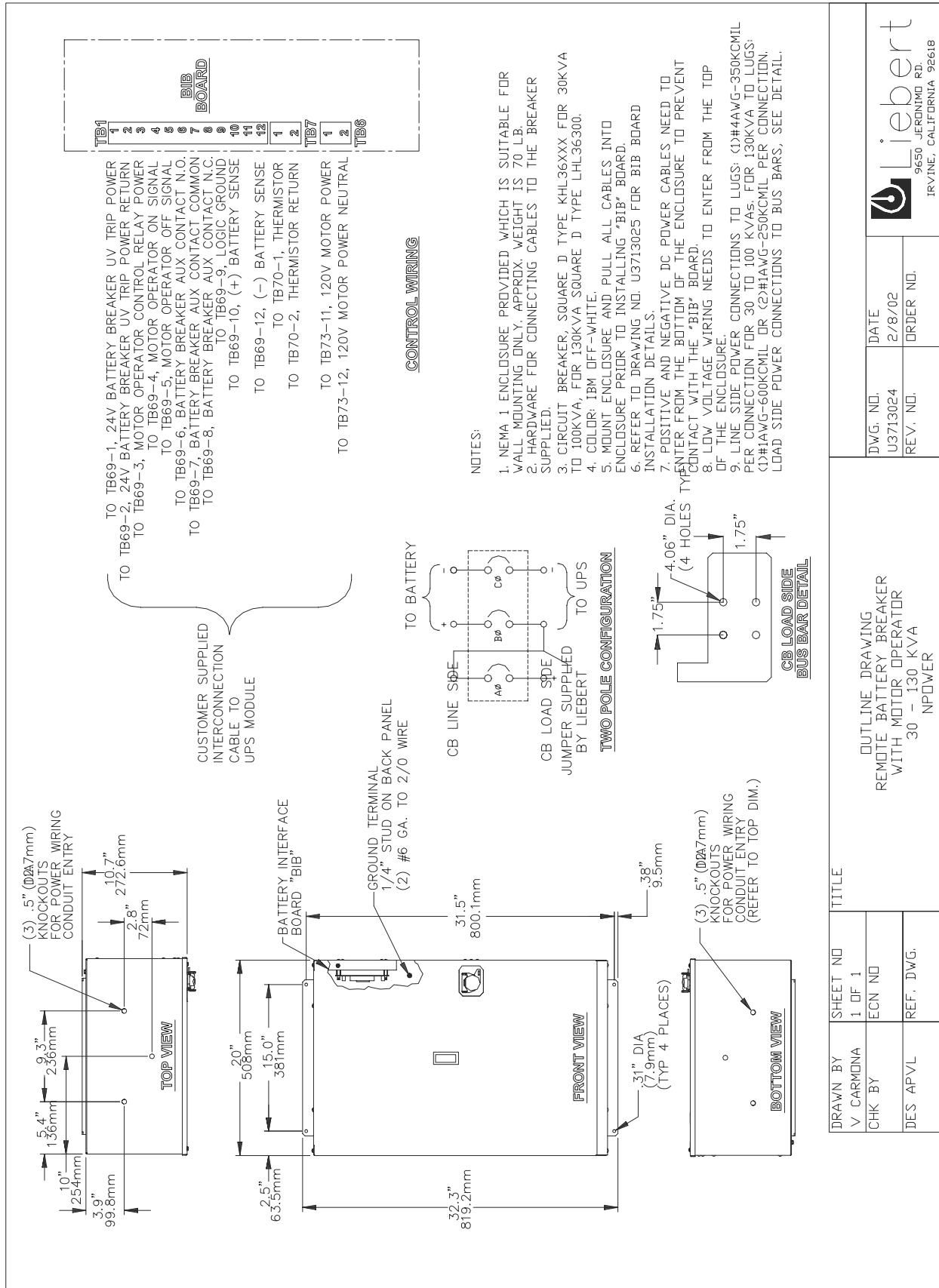


Figure 33 Outline Drawing, Remote Battery Breaker with Motor Operator, 30 - 130 kVA

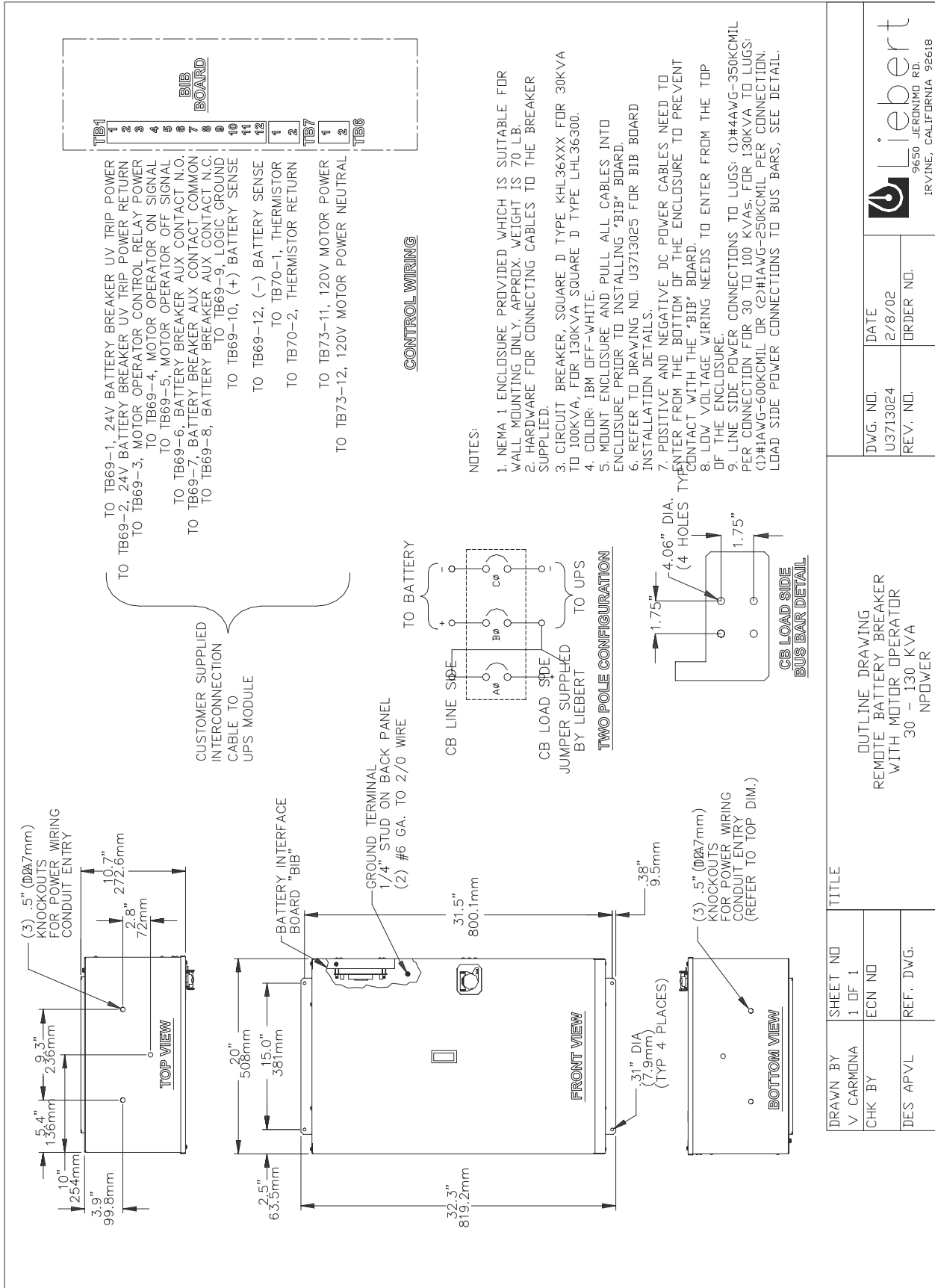
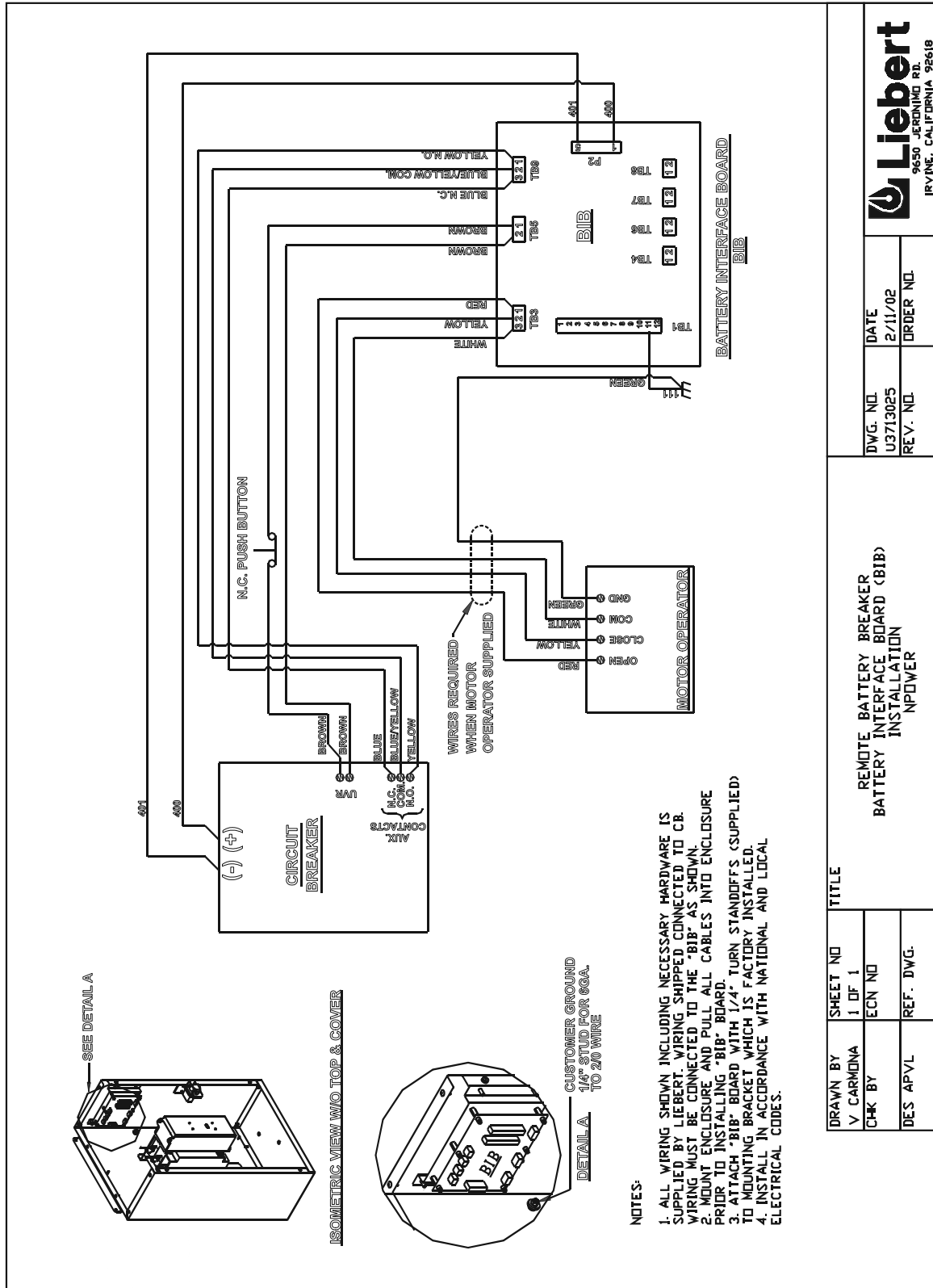


Figure 34 Outline Drawing, Remote Battery Breaker with BIB Installed



U3713025
2/11/02
ORDER NO.
REV. NO.

REMOTE BATTERY BREAKER
BATTERY INTERFACE BOARD (BIB)
INSTALLATION
POWER

DRAWN BY: V. CARMONA
CHK BY:
DES. APVL:

SHEET NO: 1 OF 1
ECN NO:
REF. DWG.:

Figure 35 Outline Drawing, Remote Alarm Status Panel

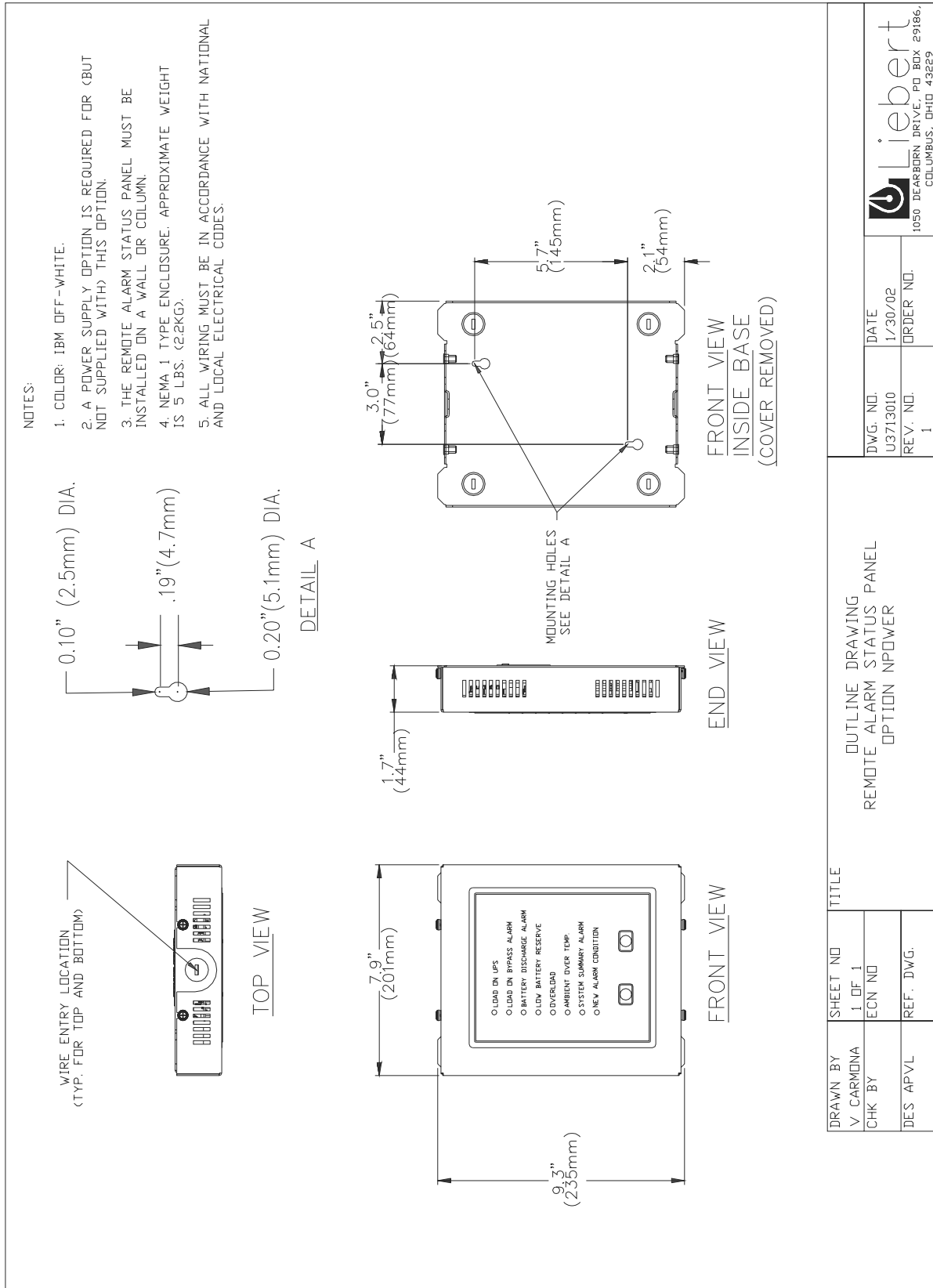
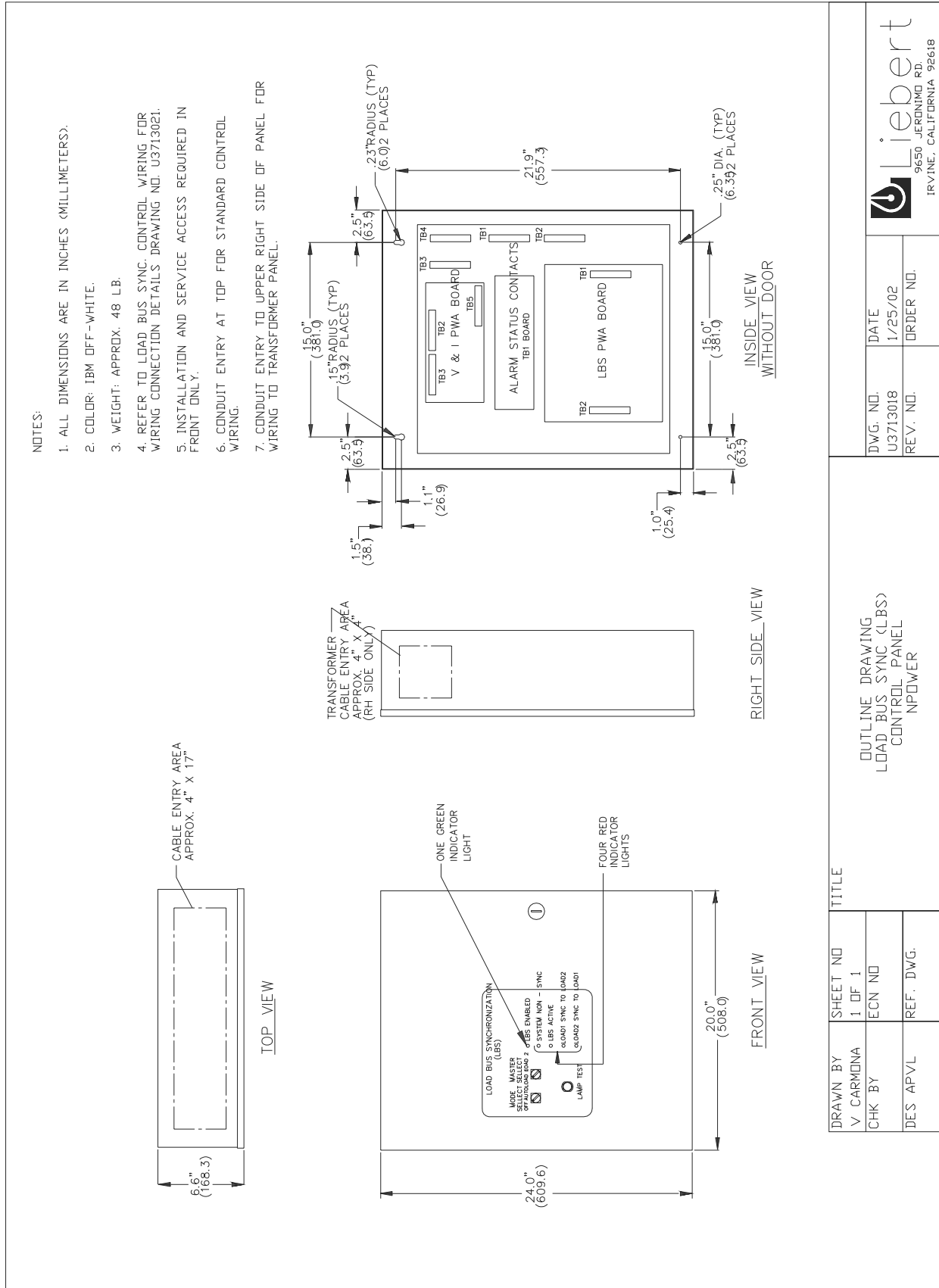


Figure 36 Outline Drawing, LBS Control Panel



DRAWN BY	SHEET NO	TITLE
V. CARMONA	1 OF 1	OUTLINE DRAWING LOAD BUS SYNC (LBS) CONTROL PANEL POWER
CHK BY	ECN NO	
DES APVL	REF. DWG.	


DWG. NO.	DATE	 Liebert 9650 JERONIMO RD. IRVINE, CALIFORNIA 92618
U3713018	1/25/02	
REV. NO.	ORDER NO.	
		FILE NAME: DPTIDNS-U3713018

Figure 37 Outline Drawing, LBS Alarm Status Contacts

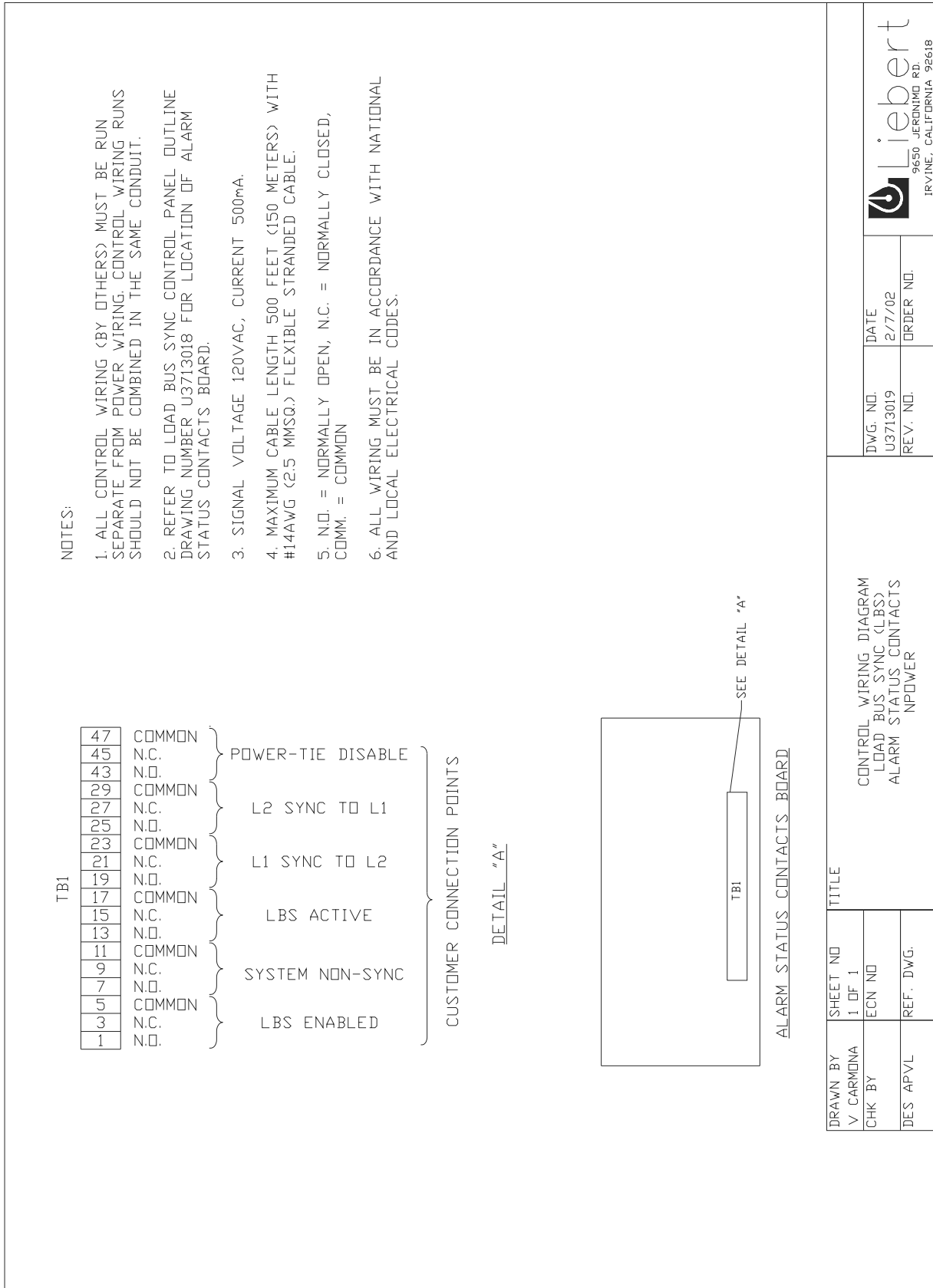
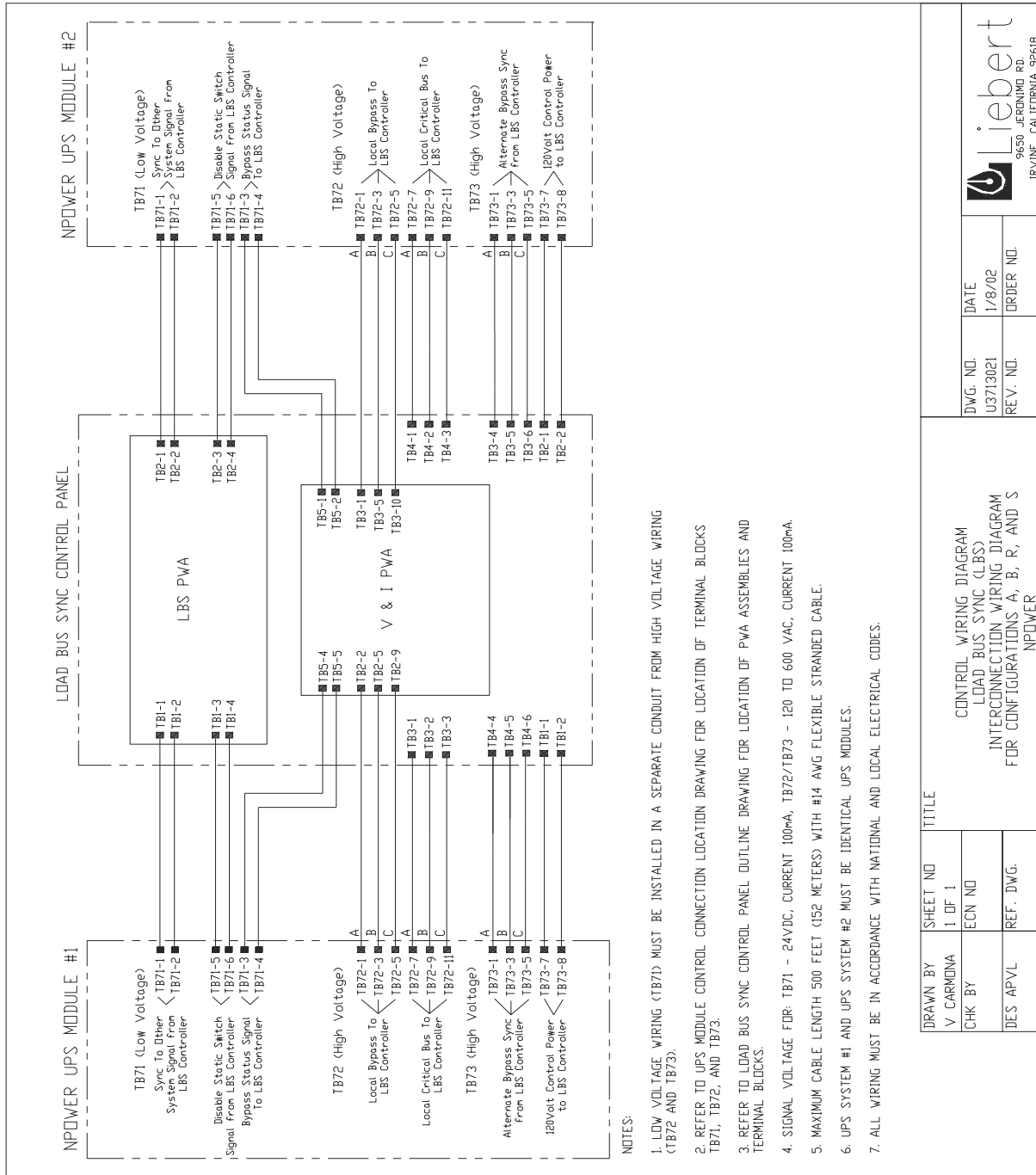


Figure 39 Control Wiring, LBS Interconnection Wiring Diagram for Configs A, B, R, S




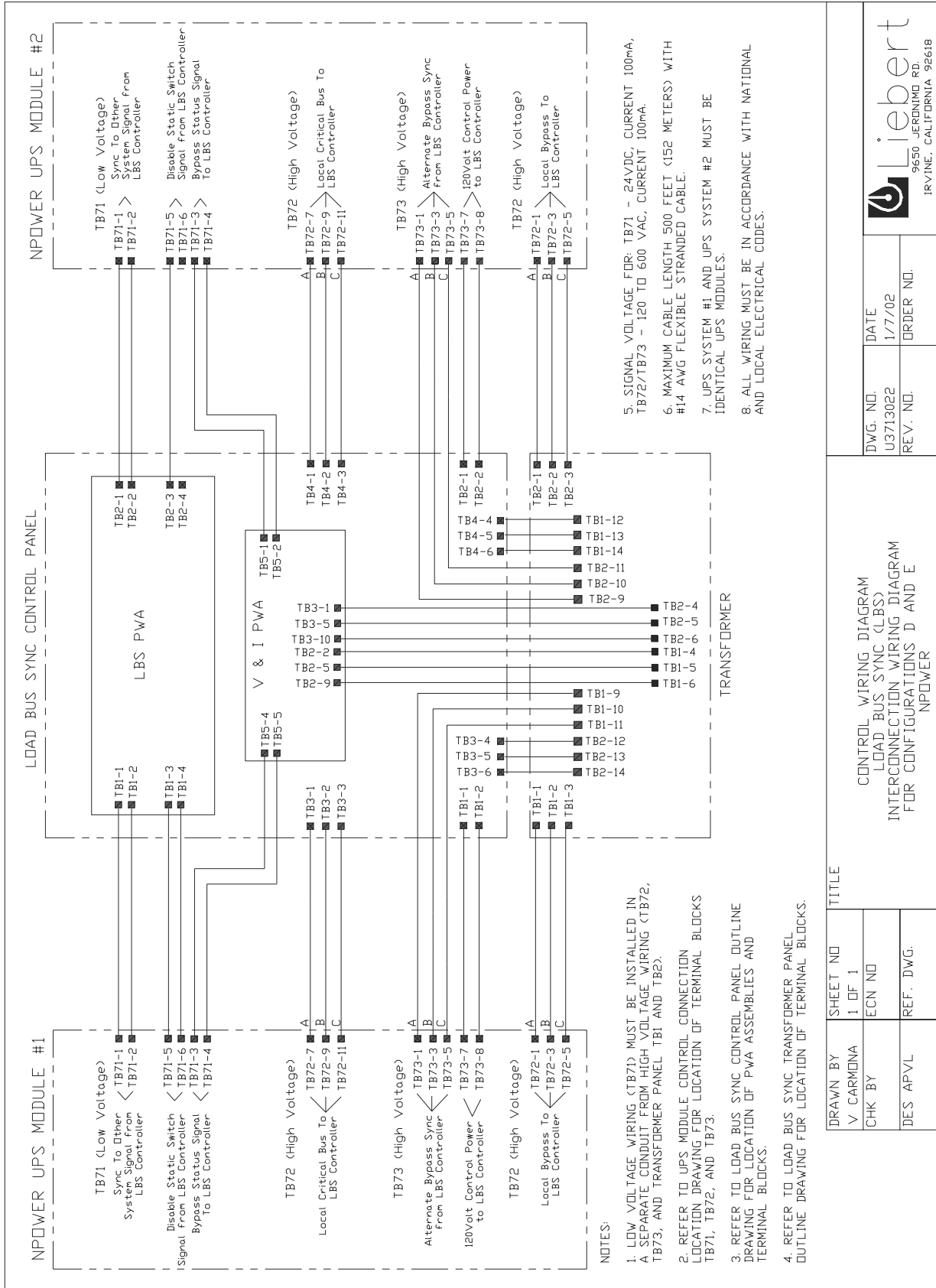
DRAWN BY V. CARMONA		SHEET NO 1 OF 1		TITLE CONTROL WIRING DIAGRAM LOAD BUS SYNC (LBS) INTERCONNECTION WIRING DIAGRAM FOR CONFIGURATIONS A, B, R, AND S NPOWER	
CHK BY		ECN NO		DWG. NO. U3713021	DATE 1/8/02
DES. APVL		REF. DWG.		REV. NO.	ORDER NO.
 9650 JERONIMO RD. IRVINE, CALIFORNIA 92618					
FILE NAME: OPTIDBS\U3713021					

Figure 40 Control Wiring, LBS Interconnection Wiring Diagram for Configs D, E



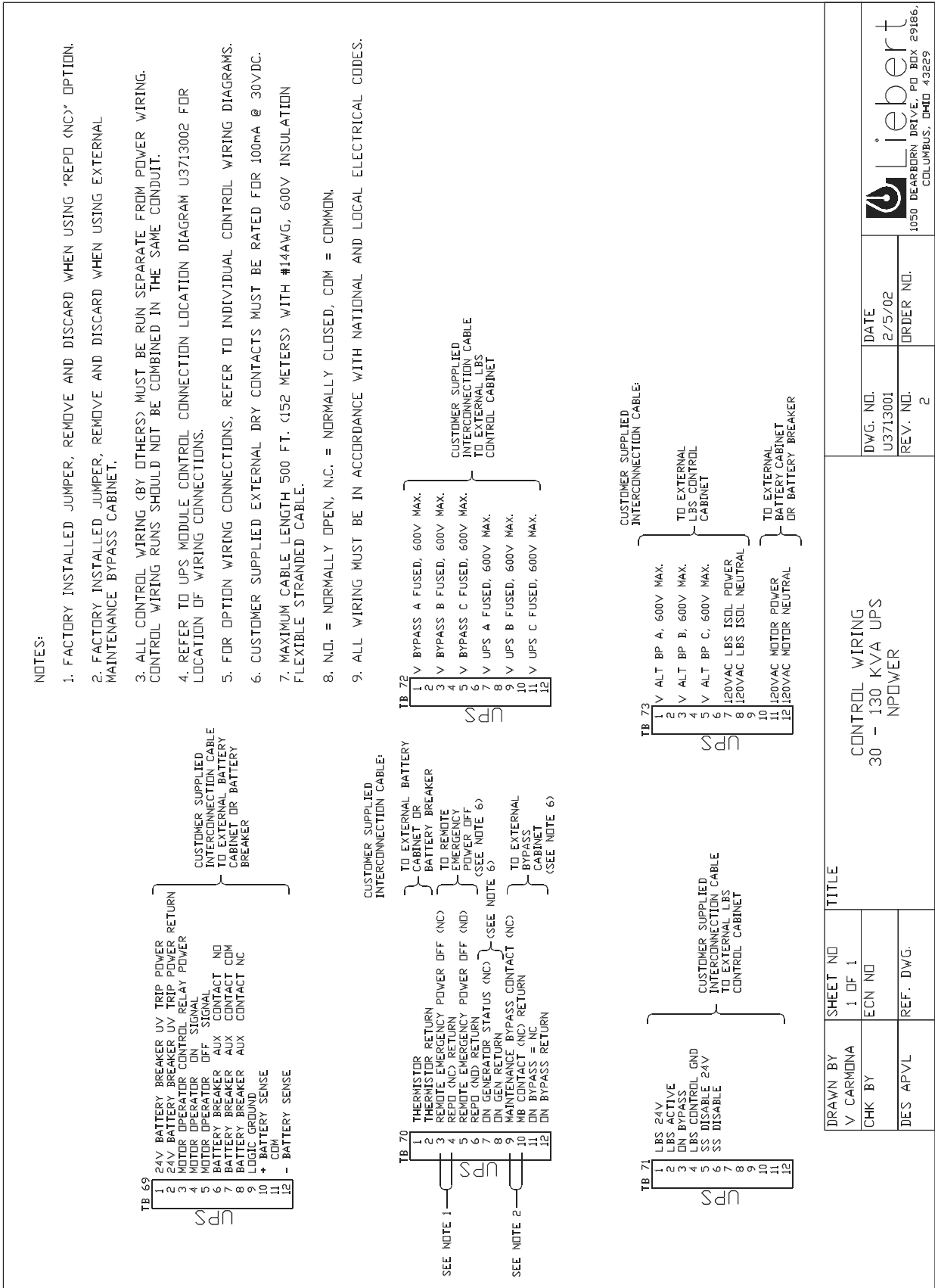
DWG. NO.	DATE
U3713022	1/7/02
REV. NO.	ORDER NO.

CONTROL WIRING DIAGRAM
LOAD BUS SYNC (LBS)
INTERCONNECTION WIRING DIAGRAM
FOR CONFIGURATIONS D AND E
NPOWER

DRAWN BY	SHEET NO	TITLE
V. CARMONA	1 OF 1	
CHK BY	ECN NO	
DES APVL	REF. DWG.	

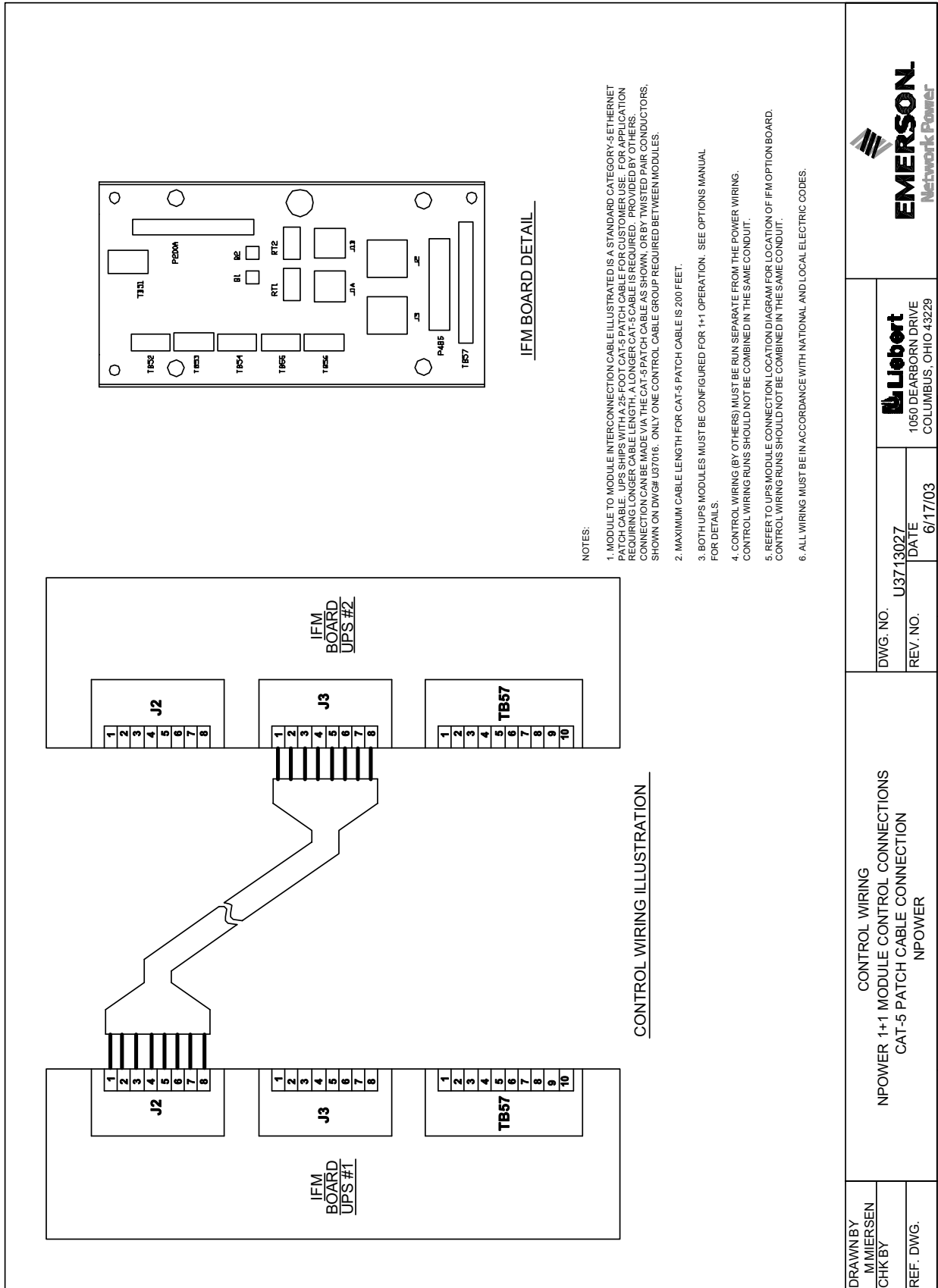


Figure 41 Control Wiring, 30 - 130 kVA UPS



DRAWN BY V. CARMONA		SHEET NO 1 OF 1		TITLE CONTROL WIRING 30 - 130 KVA UPS NPOWER	
CHK BY		ECN NO		DWG. NO. U3713001	
DES APVL		REF. DWG.		DATE 2/5/02	
				ORDER NO.	
				REV. NO. 2	
				FILE NAME: OPTINSU3713001	
				 1050 DEARBORN DRIVE, PO. BOX 29186, COLUMBUS, OHIO 43229	

Figure 42 Control Wiring, 1+1 Category 5 Patch Cable Connection



DRAWN BY
MMIERSEN
CHK BY

CONTROL WIRING
NPOWER 1+1 MODULE CONTROL CONNECTIONS
CAT-5 PATCH CABLE CONNECTION
NPOWER

DWG. NO. U3713027
REV. NO. DATE 6/17/03

Liobert
1050 DEARBORN DRIVE
COLUMBUS, OHIO 43229



FILE NAME: NpowerDrawings\Options\1+1\U3713027(0)

Figure 43 Control Wiring, 1+1 Twisted-Pair Cable Connection

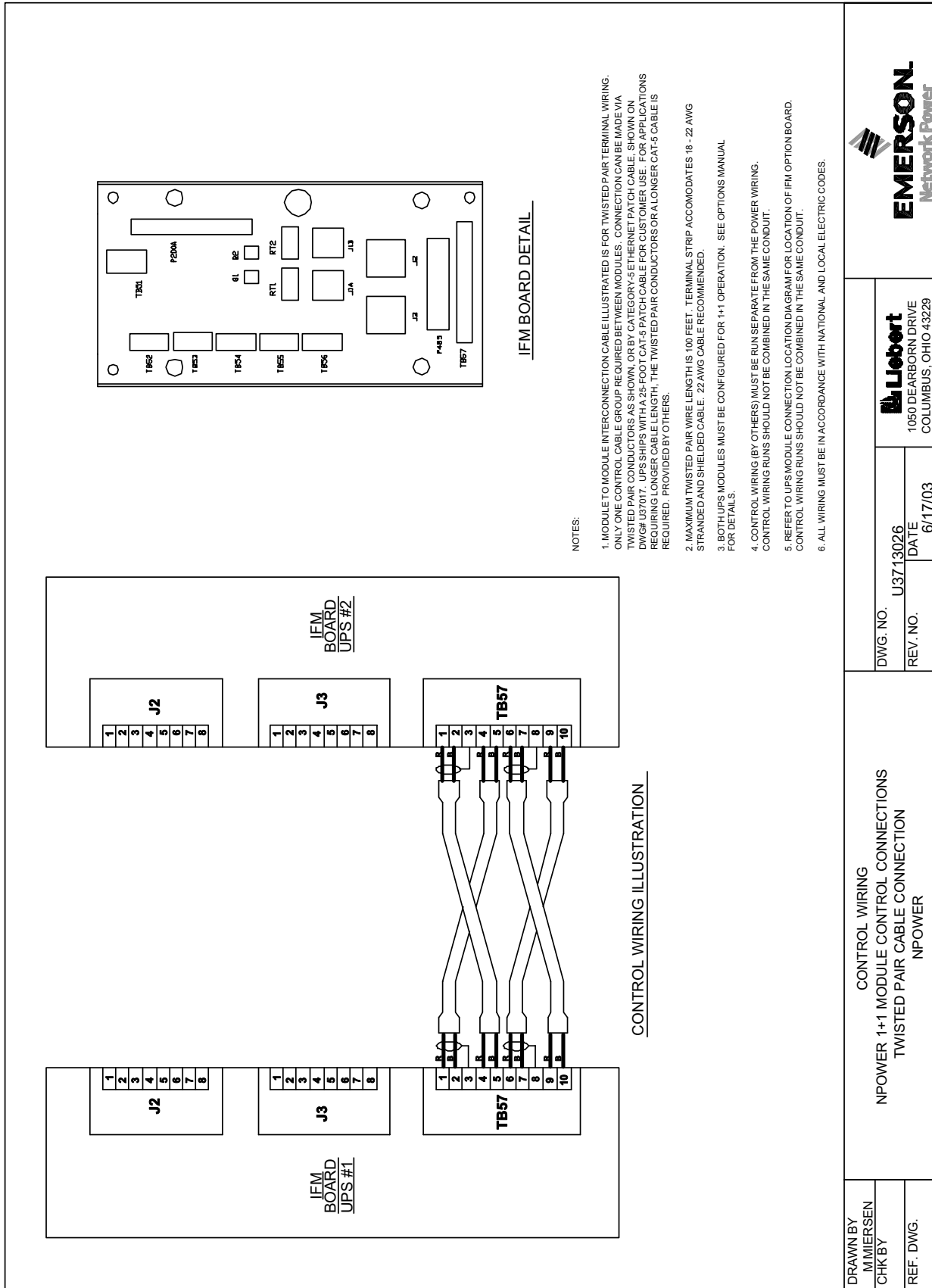


Figure 44 Control Wiring, Remote Alarm Status Panel Option

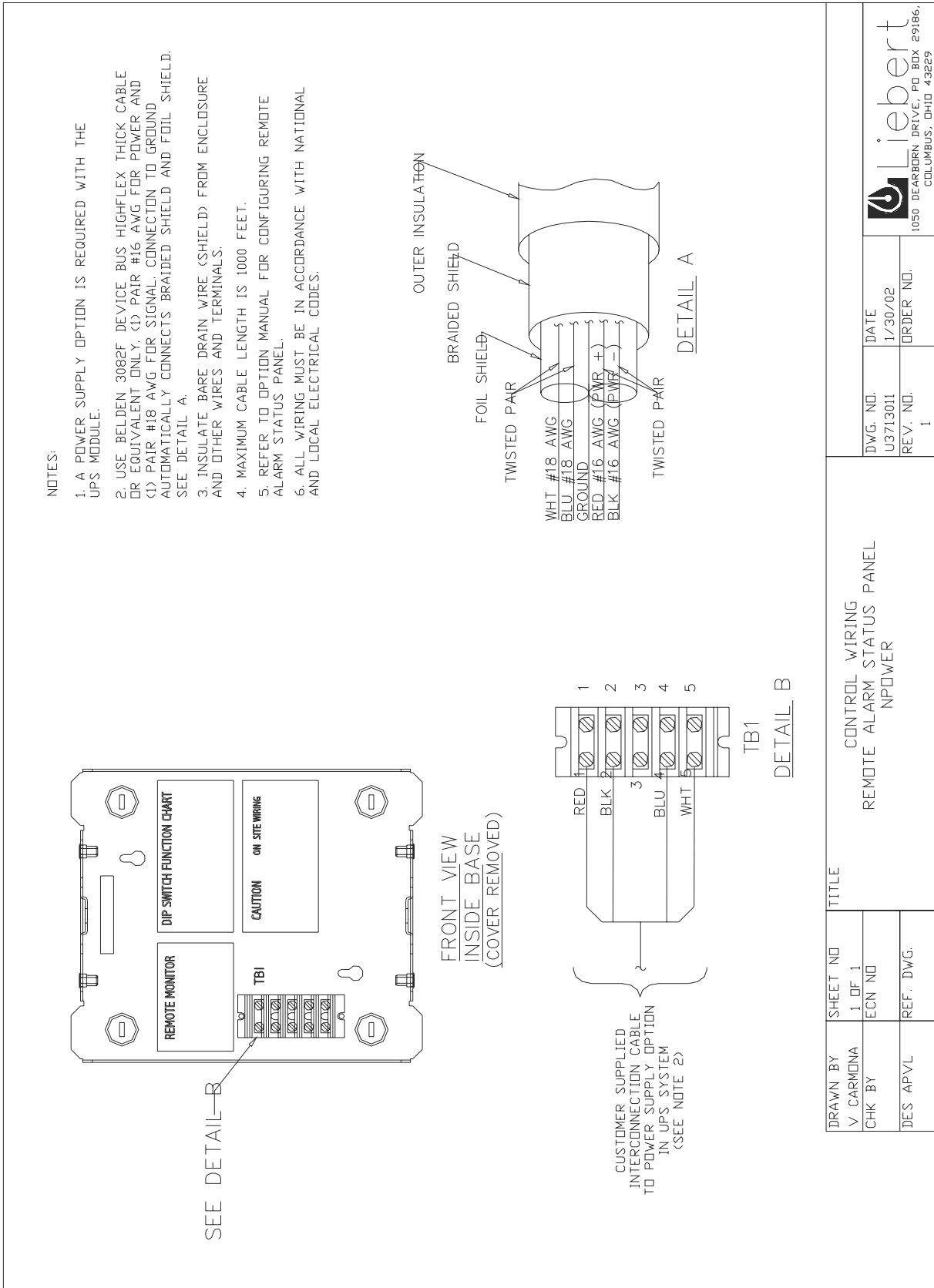


Figure 45 Control Wiring, 2 or 3 Remote Alarm Status Panels

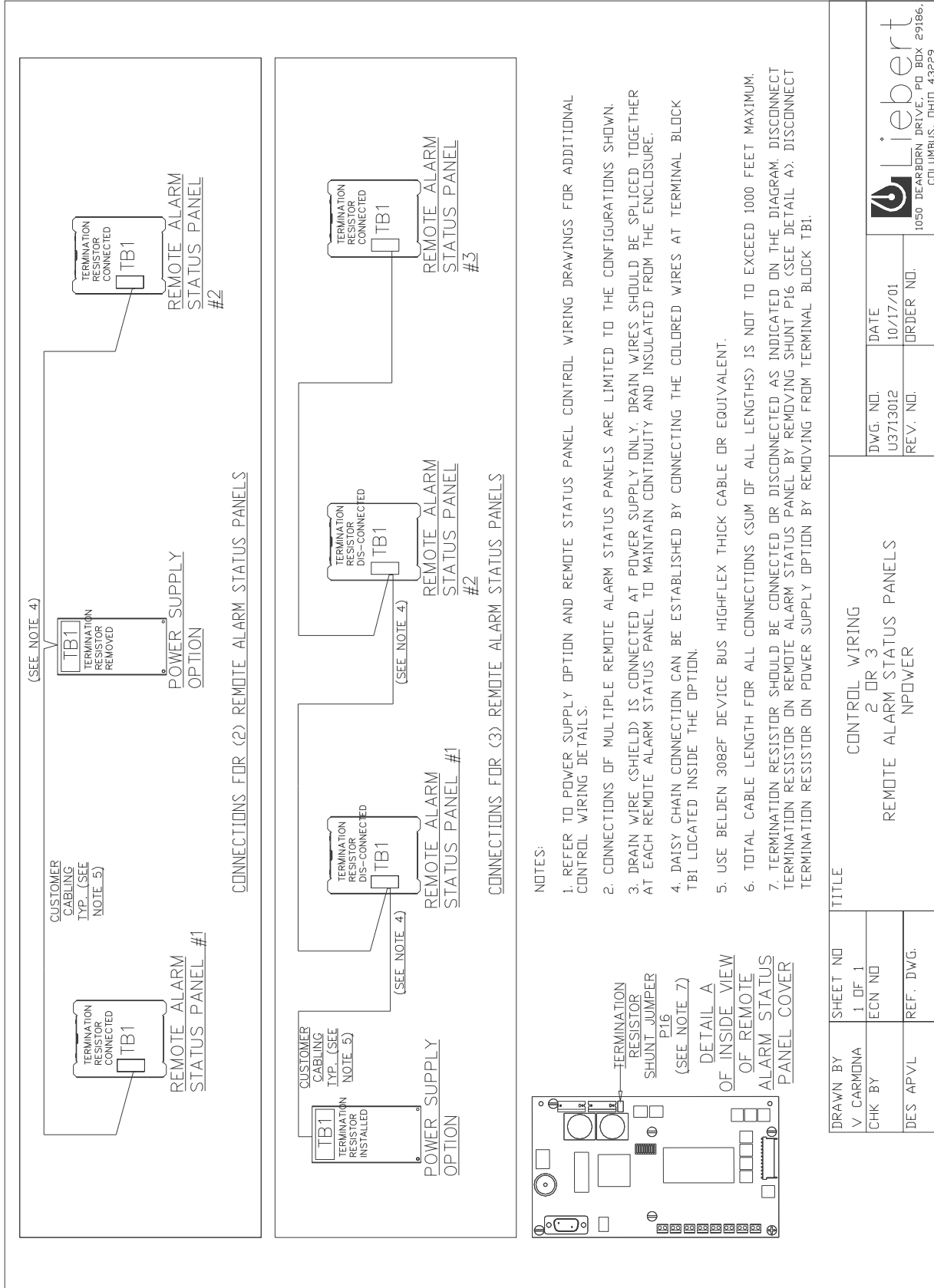


Figure 46 Control Wiring, 3 Remote Alarm Status Panels with Stub Connections

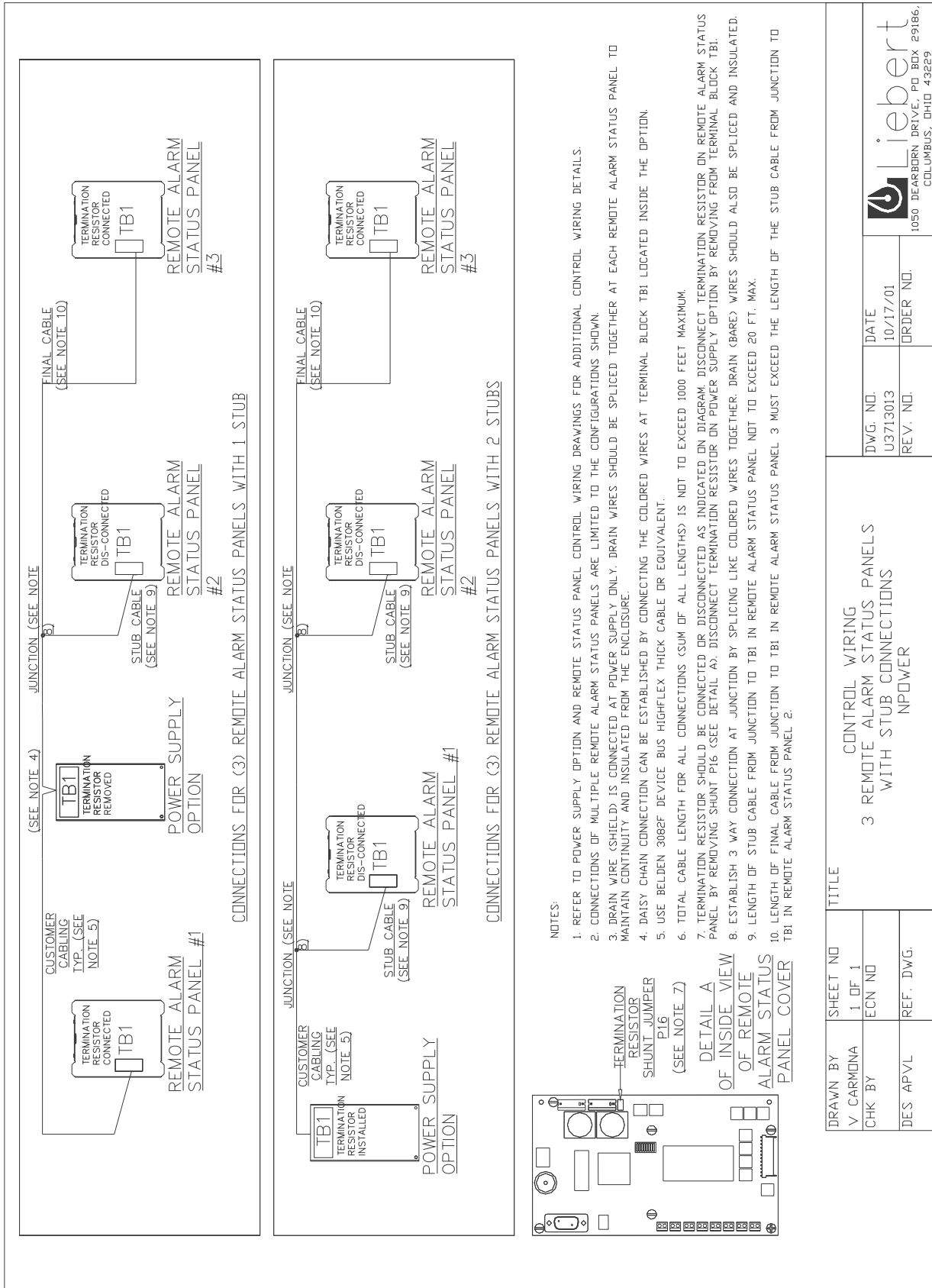


Figure 47 Control Wiring, Site Scan Interface

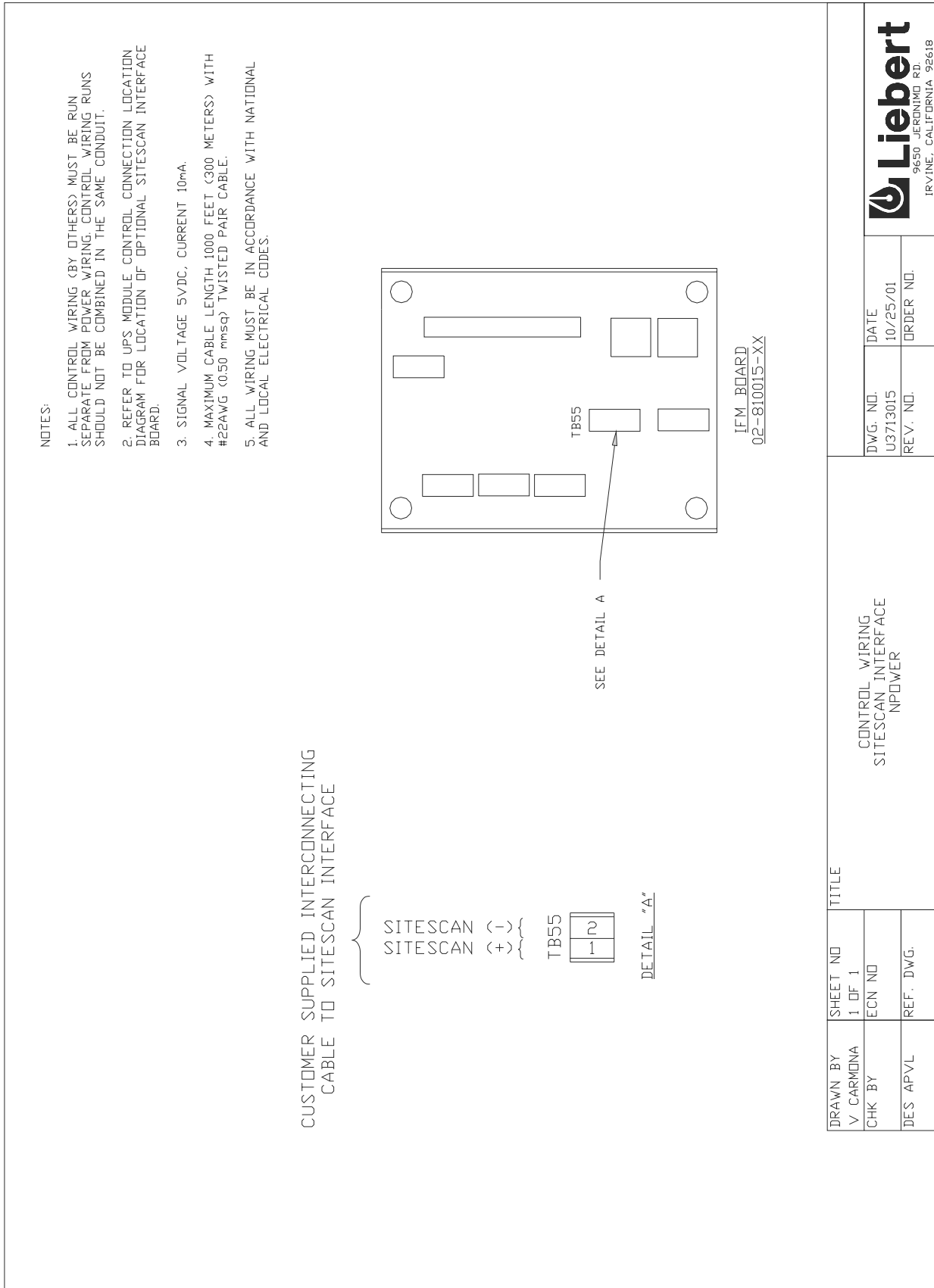


Figure 48 Control Wiring, Programmable Relay Board Option

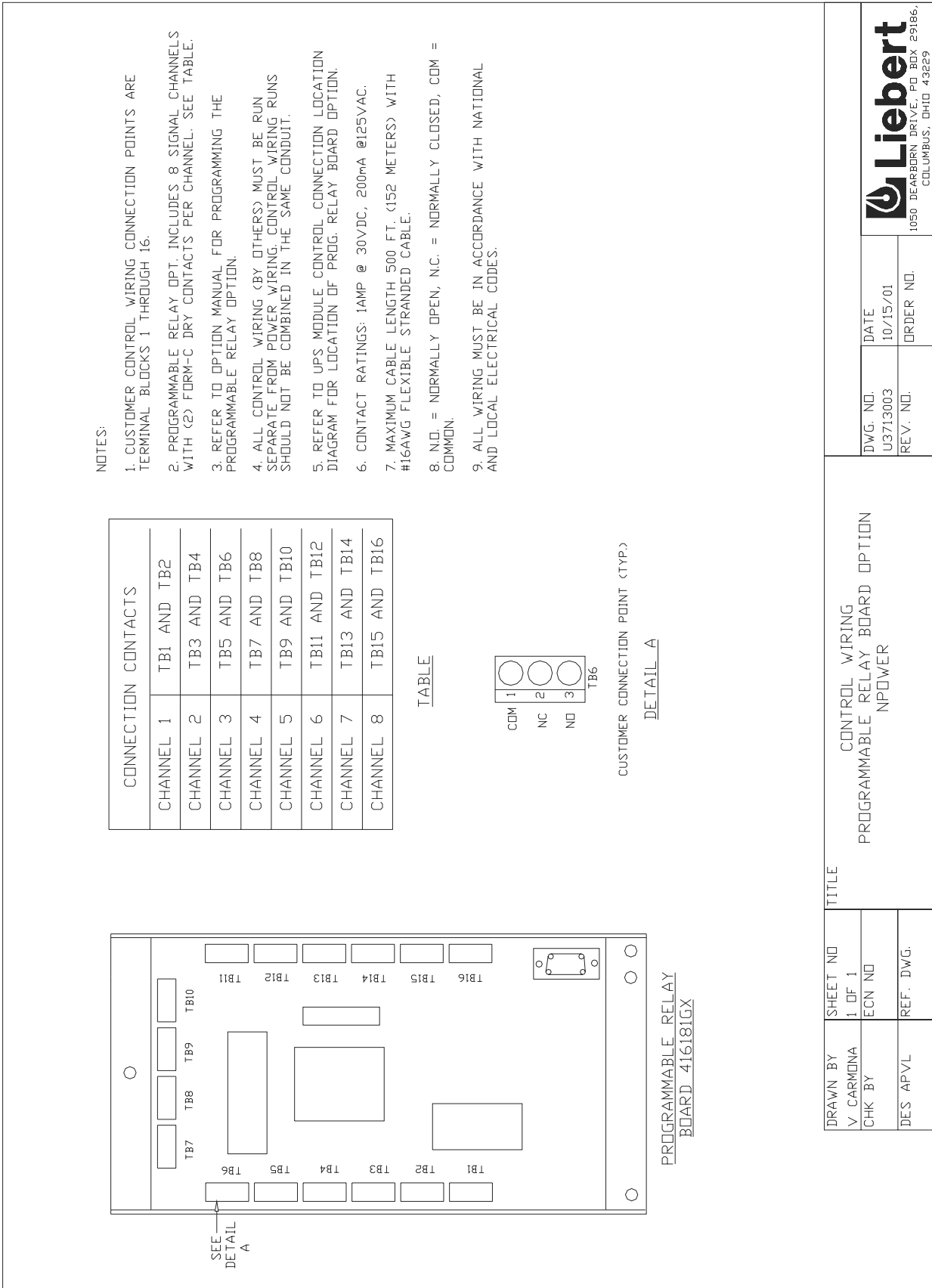
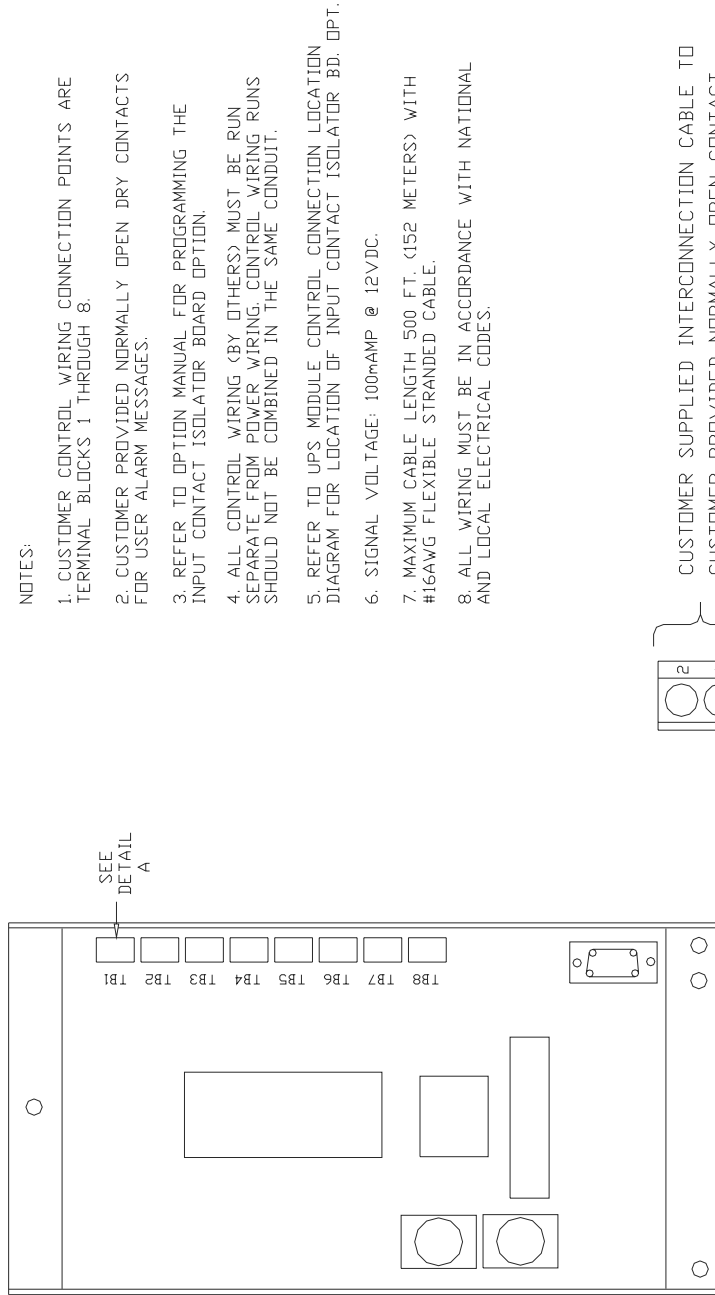
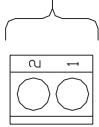


Figure 49 Control Wiring, Input Contact Isolator Board



INPUT CONTACT ISOLATOR BOARD
02-810012-XX



CUSTOMER CONNECTION POINT (TYP)
DETAIL A

NOTES:

1. CUSTOMER CONTROL WIRING CONNECTION POINTS ARE TERMINAL BLOCKS 1 THROUGH 8.
2. CUSTOMER PROVIDED NORMALLY OPEN DRY CONTACTS FOR USER ALARM MESSAGES.
3. REFER TO OPTION MANUAL FOR PROGRAMMING THE INPUT CONTACT ISOLATOR BOARD OPTION.
4. ALL CONTROL WIRING (BY OTHERS) MUST BE RUN SEPARATE FROM POWER WIRING. CONTROL WIRING RUNS SHOULD NOT BE COMBINED IN THE SAME CONDUIT.
5. REFER TO UPS MODULE CONTROL CONNECTION LOCATION DIAGRAM FOR LOCATION OF INPUT CONTACT ISOLATOR BD. OPT.
6. SIGNAL VOLTAGE: 100mA @ 12VDC.
7. MAXIMUM CABLE LENGTH 500 FT. (152 METERS) WITH #16AWG FLEXIBLE STRANDED CABLE.
8. ALL WIRING MUST BE IN ACCORDANCE WITH NATIONAL AND LOCAL ELECTRICAL CODES.

CUSTOMER SUPPLIED INTERCONNECTION CABLE TO CUSTOMER PROVIDED NORMALLY OPEN CONTACT.

DRAWN BY V. CARMONA	SHEET NO 1 OF 1	TITLE CONTROL WIRING INPUT CONTACT ISOLATOR BOARD	
	CHK BY	ECN NO	OPTION NPOWER
DES APVL	REF. DWG.	DWG. NO. U3713004	DATE 10/15/01
		REV. NO.	ORDER NO.



FILE NAME: OPTIONS\U3713004

Figure 50 Control Wiring, NIC Option

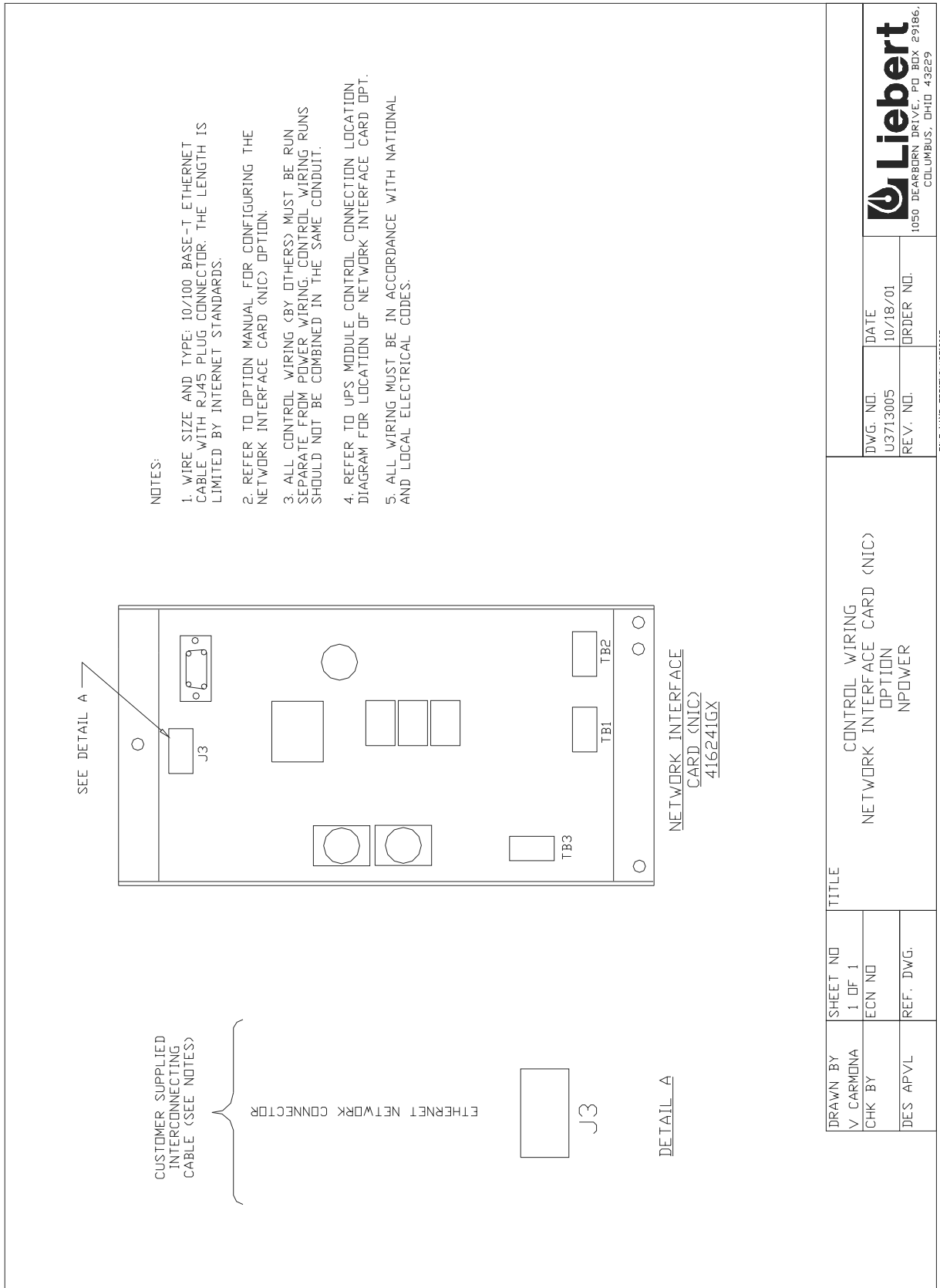
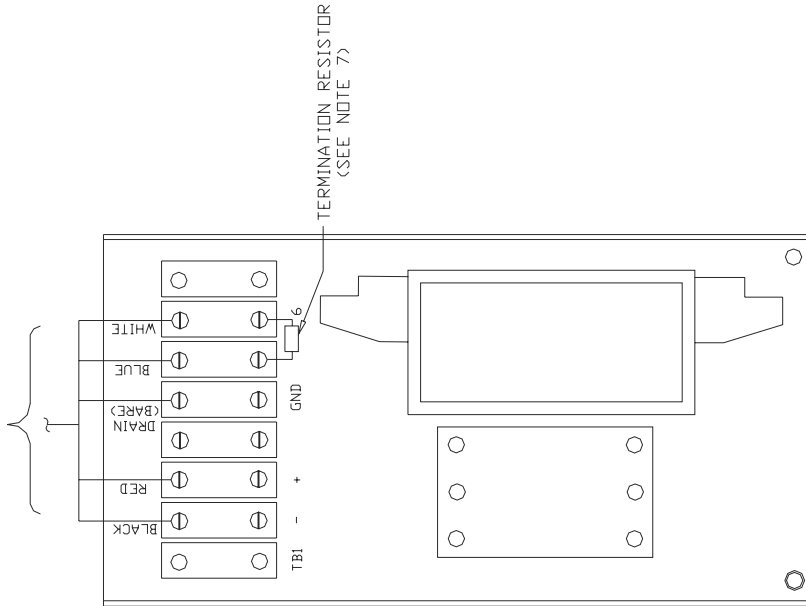


Figure 51 Control Wiring, Power Supply Option

CUSTOMER SUPPLIED
INTERCONNECTING CABLE TO
REMOTE ALARM STATUS PANEL.



NOTES:

1. CONNECTION SHOWN IS FOR ONE REMOTE ALARM STATUS PANEL.
2. USE BELDEN 3082F DEVICE BUS HIGHFLEX THICK CABLE OR EQUIVALENT.
3. REFER TO OPTION MANUAL FOR CONFIGURING OPTION POWER SUPPLY.
4. ALL CONTROL WIRING (BY OTHERS) MUST BE RUN SEPARATE FROM POWER WIRING. CONTROL WIRING RUNS SHOULD NOT BE COMBINED IN THE SAME CONDUIT.
5. REFER TO UPS MODULE CONTROL CONNECTION LOCATION DIAGRAM FOR LOCATION OF WIRING CONNECTIONS.
6. ALL WIRING MUST BE IN ACCORDANCE WITH NATIONAL AND LOCAL ELECTRICAL CODES.
7. TERMINATION RESISTOR MUST BE DISCONNECTED FOR SOME CONFIGURATIONS WITH 2 OR MORE REMOTE ALARM STATUS PANELS. REFER TO CONTROL WIRING DRAWINGS FOR 2 OR MORE REMOTE ALARM STATUS PANELS FOR DETAILS.

DRAWN BY	SHEET NO	TITLE
V. CARMONA	1 OF 1	CONTROL WIRING POWER SUPPLY OPTION NPOWER
CHK BY	ECN NO	
DES. APVL	REF. DWG.	

DWG. NO.	DATE
U3713006	10/17/01
REV. NO.	ORDER NO.



FILE NAME: OPTIDNS\U3713006

Figure 52 Control Wiring, Internal Modem Option

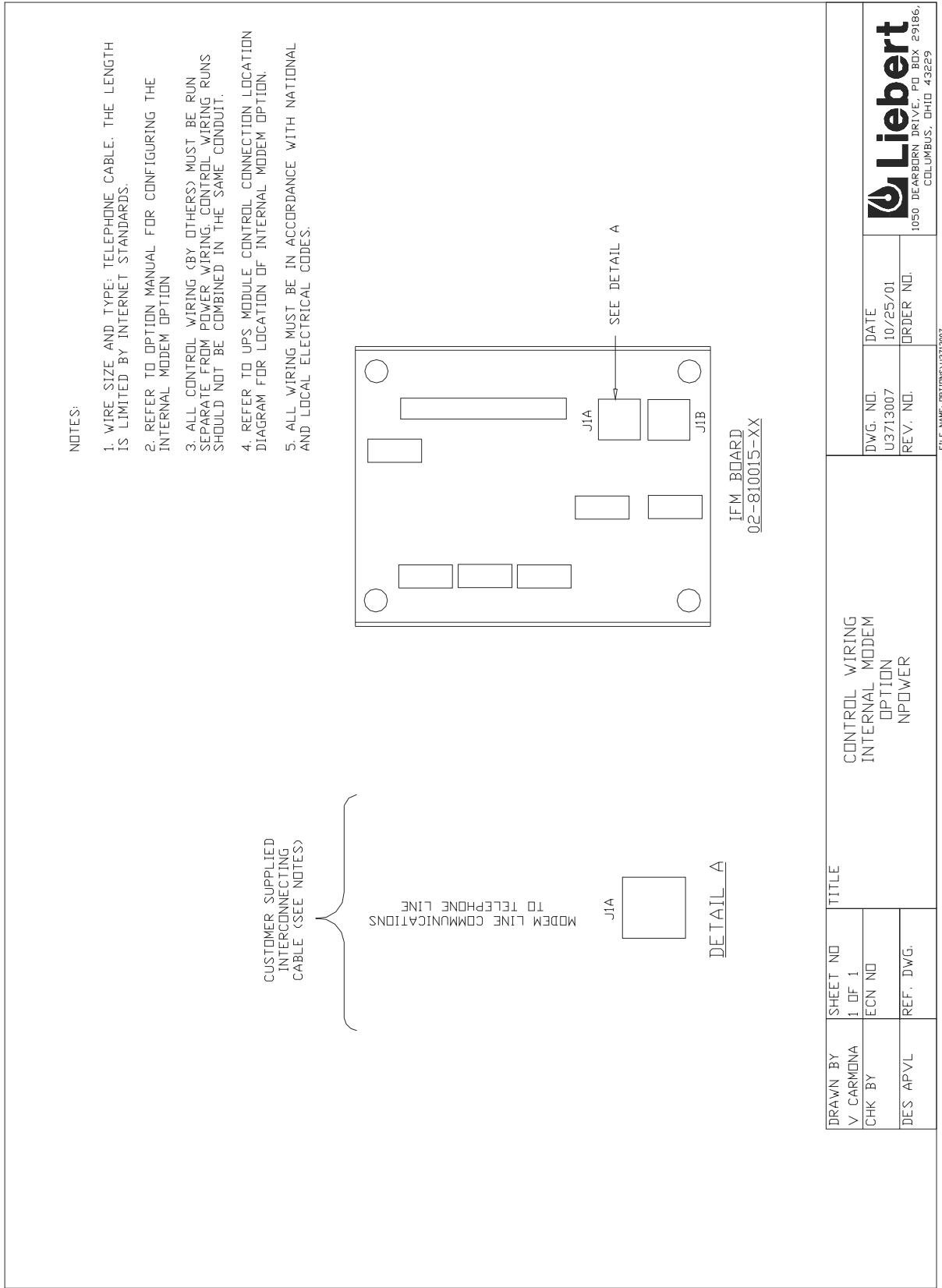


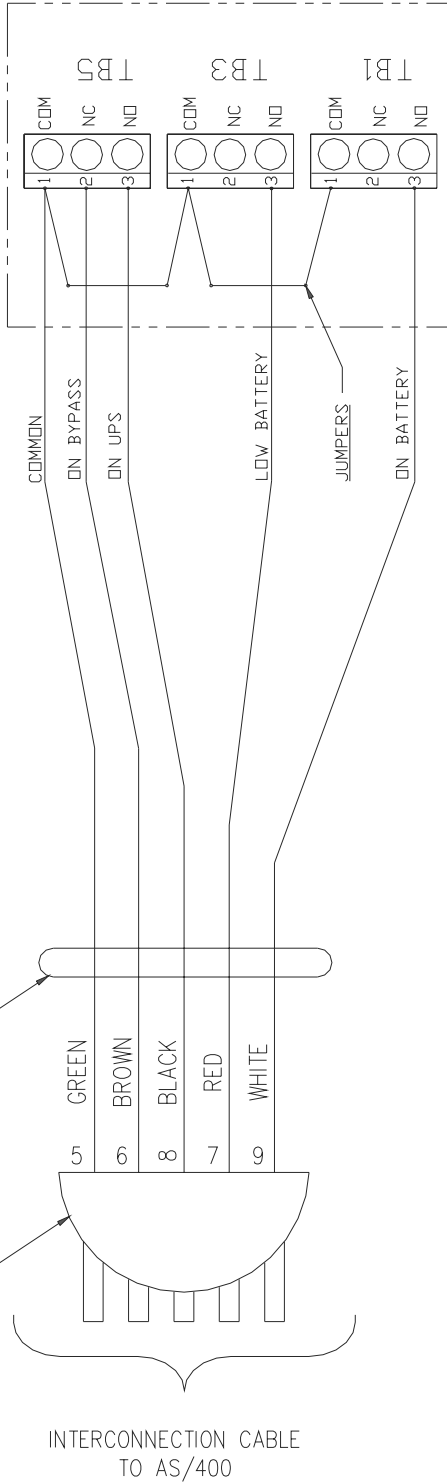
Figure 53 Control Wiring, AS 400 Signal Cable Option

NOTES:

1. THE PROGRAMMABLE RELAY BOARD OPTION IS REQUIRED FOR (BUT NOT SUPPLIED WITH) THIS OPTION.
2. REFER TO THE CONTROL WIRING DRAWING FOR THE PROGRAMMABLE RELAY BOARD OPTION FOR FURTHER DETAILS REGARDING CUSTOMER CONNECTIONS.
3. WIRE BARE ENDS OF THE AS/400 SIGNAL CABLE TO THE OPTIONAL PROGRAMMABLE RELAY BOARD LOCATED INSIDE THE UPS.
4. PROGRAM RELAY CHANNELS 1, 2, AND 3 ON THE PROGRAMMABLE RELAY BOARD FOR THE ALARM CONDITIONS SHOWN.
5. ALL CONTROL WIRING (BY OTHERS) MUST BE RUN SEPARATE FROM POWER WIRING. CONTROL WIRING RUNS SHOULD NOT BE COMBINED IN THE SAME CONDUIT.
6. N.O. = NORMALLY OPEN, N.C. = NORMALLY CLOSED, COM = COMMON.
7. ALL WIRING MUST BE IN ACCORDANCE WITH NATIONAL AND LOCAL ELECTRICAL CODES.

50 FOOT SHIELDED CABLE
NEC CL2 COMPLIANT
(PROVIDED WITH OPTION)

9-PIN D-TYPE
PLUG



PROGRAMMABLE RELAY BOARD
CUSTOMER CONNECTION POINTS

DRAWN BY	SHEET NO	TITLE
V. CARMONA	1 OF 1	CONTROL WIRING AS/400 SIGNAL CABLE OPTION NPOWER
CHK BY	ECN NO	
DES. APVL	REF. DWG.	

DWG. NO.	DATE
U3713008	10/18/01
REV. NO.	ORDER NO.



FILE NAME: OPTIONS\U3713008

Figure 54 Control Wiring, Open Wire Cable Adaptor Option

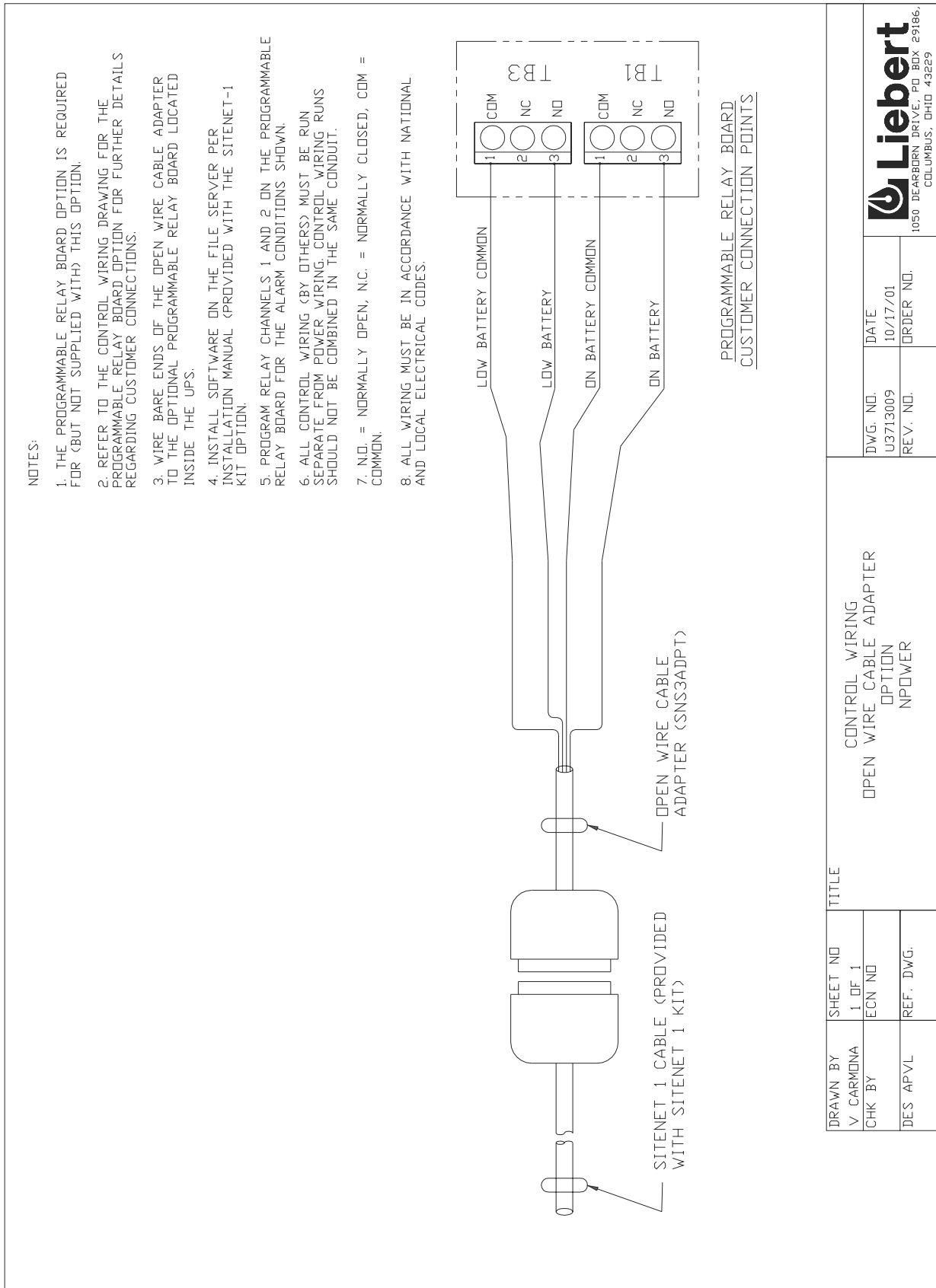


Figure 55 Control Connection Diagram 50 --130 kVA

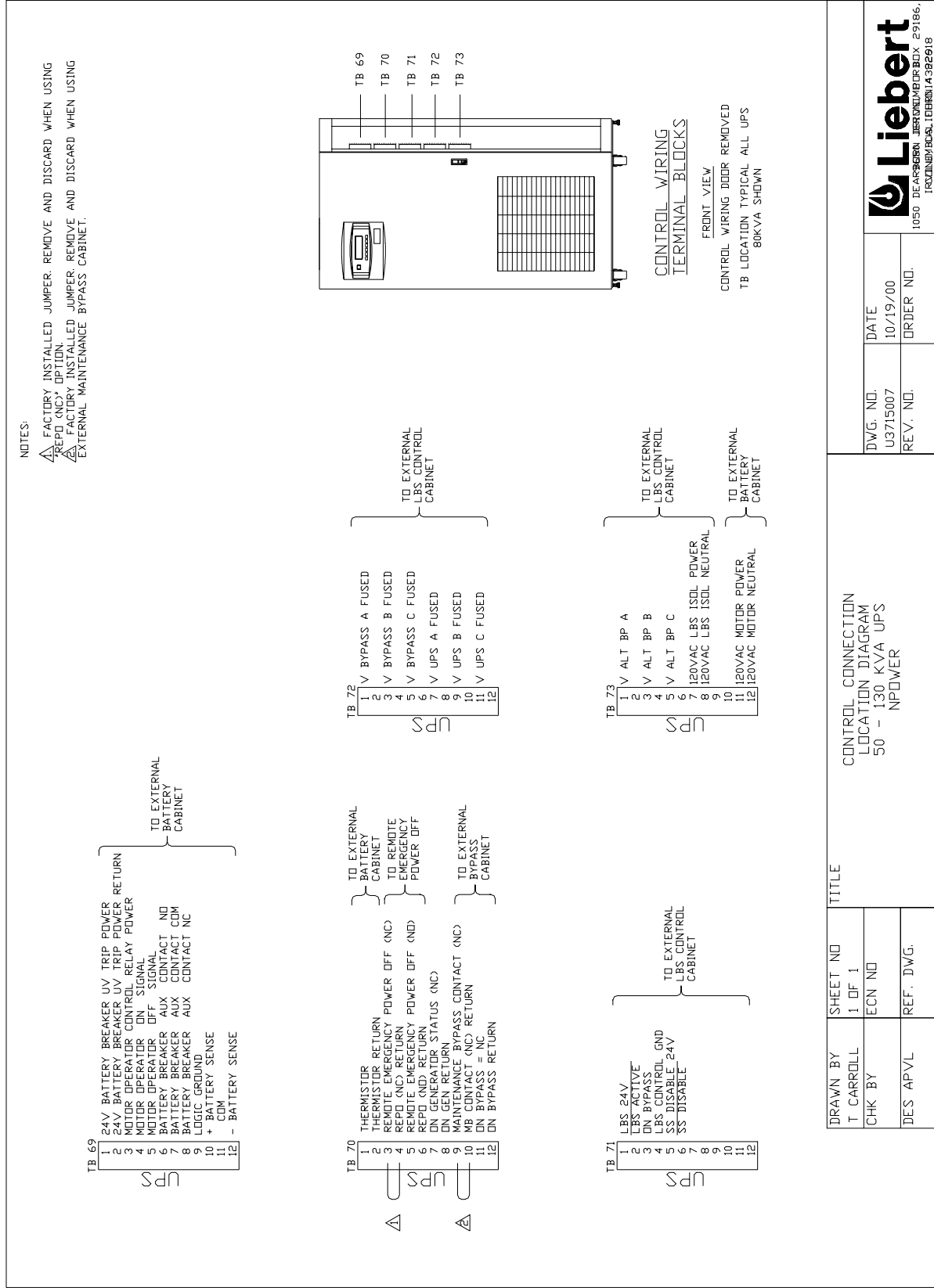
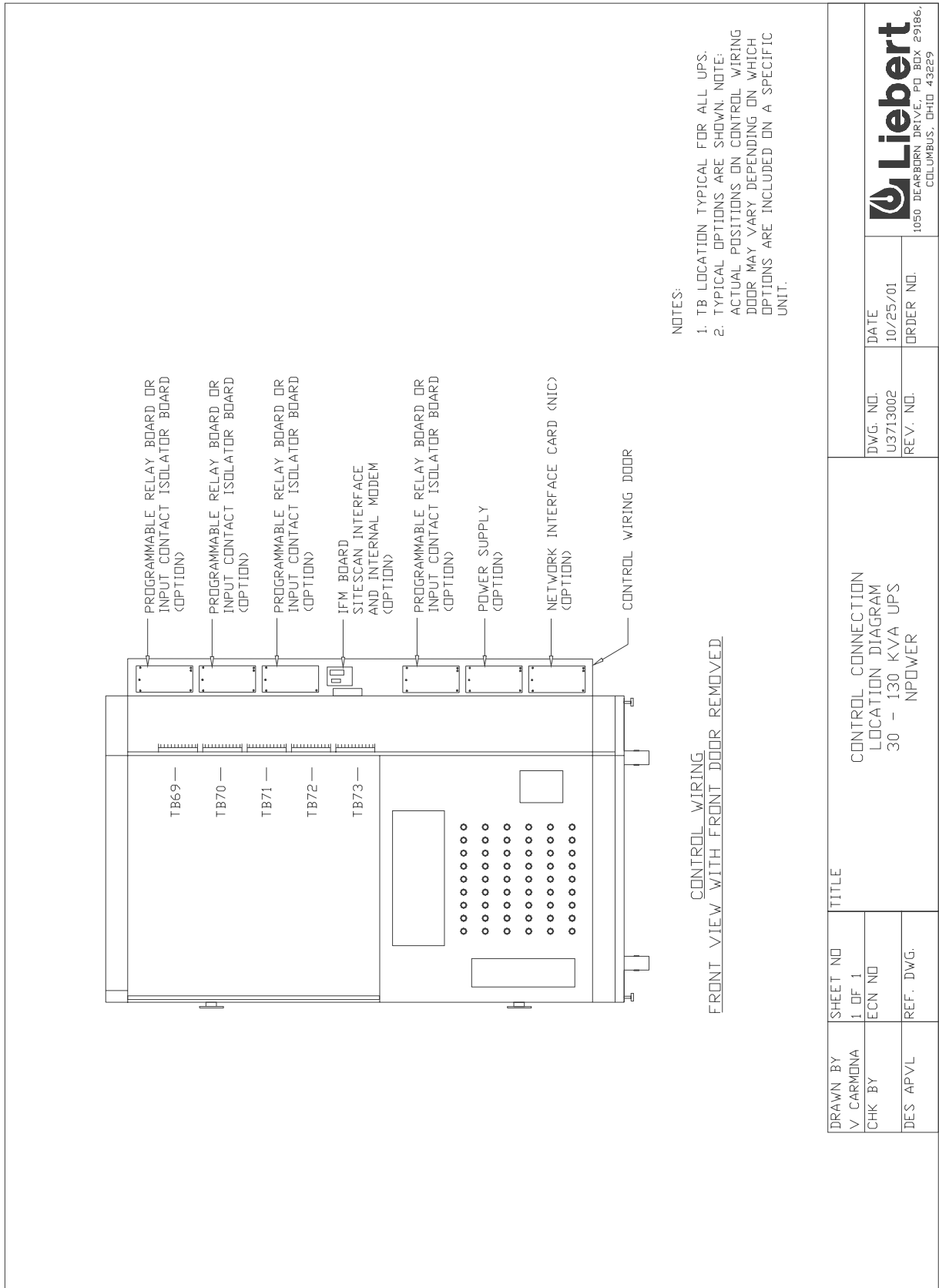


Figure 56 Control Connection Location Diagram, 30-130 kVA UPS



NOTES:
 1. TB LOCATION TYPICAL FOR ALL UPS.
 2. TYPICAL OPTIONS ARE SHOWN. NOTE: ACTUAL POSITIONS ON CONTROL WIRING DOOR MAY VARY DEPENDING ON WHICH OPTIONS ARE INCLUDED ON A SPECIFIC UNIT.

CONTROL WIRING
 FRONT VIEW WITH FRONT DOOR REMOVED

DRAWN BY V. CARMONA	SHEET NO 1 OF 1	TITLE CONTROL CONNECTION LOCATION DIAGRAM 30 - 130 KVA UPS NPOWER	
CHK BY	ECN NO	DWG. NO. U3713002	DATE 10/25/01
DES. APVL	REF. DWG.	REV. NO.	ORDER NO.



FILE NAME: OPTIONS\U3713002

Figure 57 Terminal Details, 30 - 50 kVA UPS

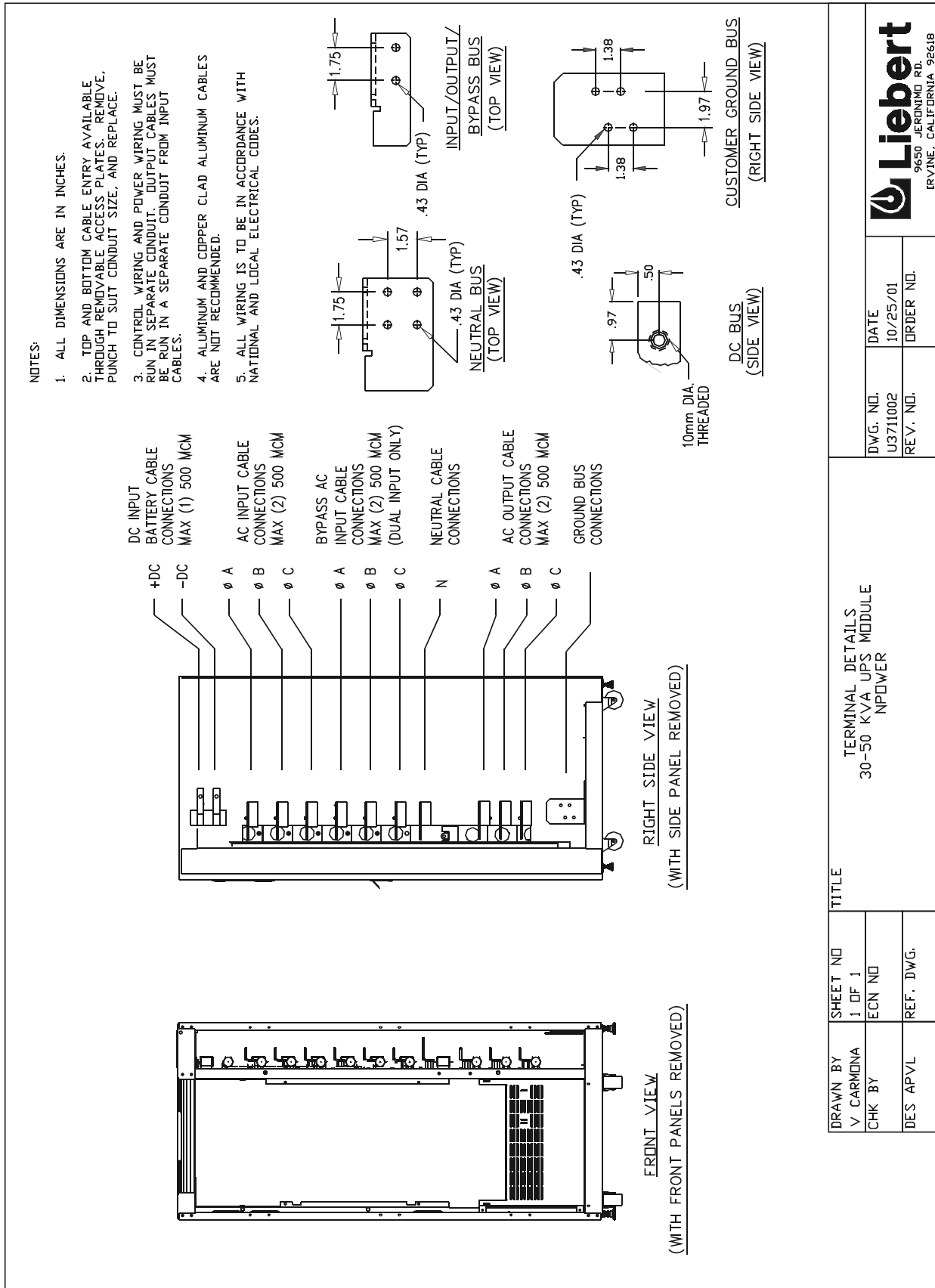


Figure 58 Terminal Details, 65 - 80 kVA UPS

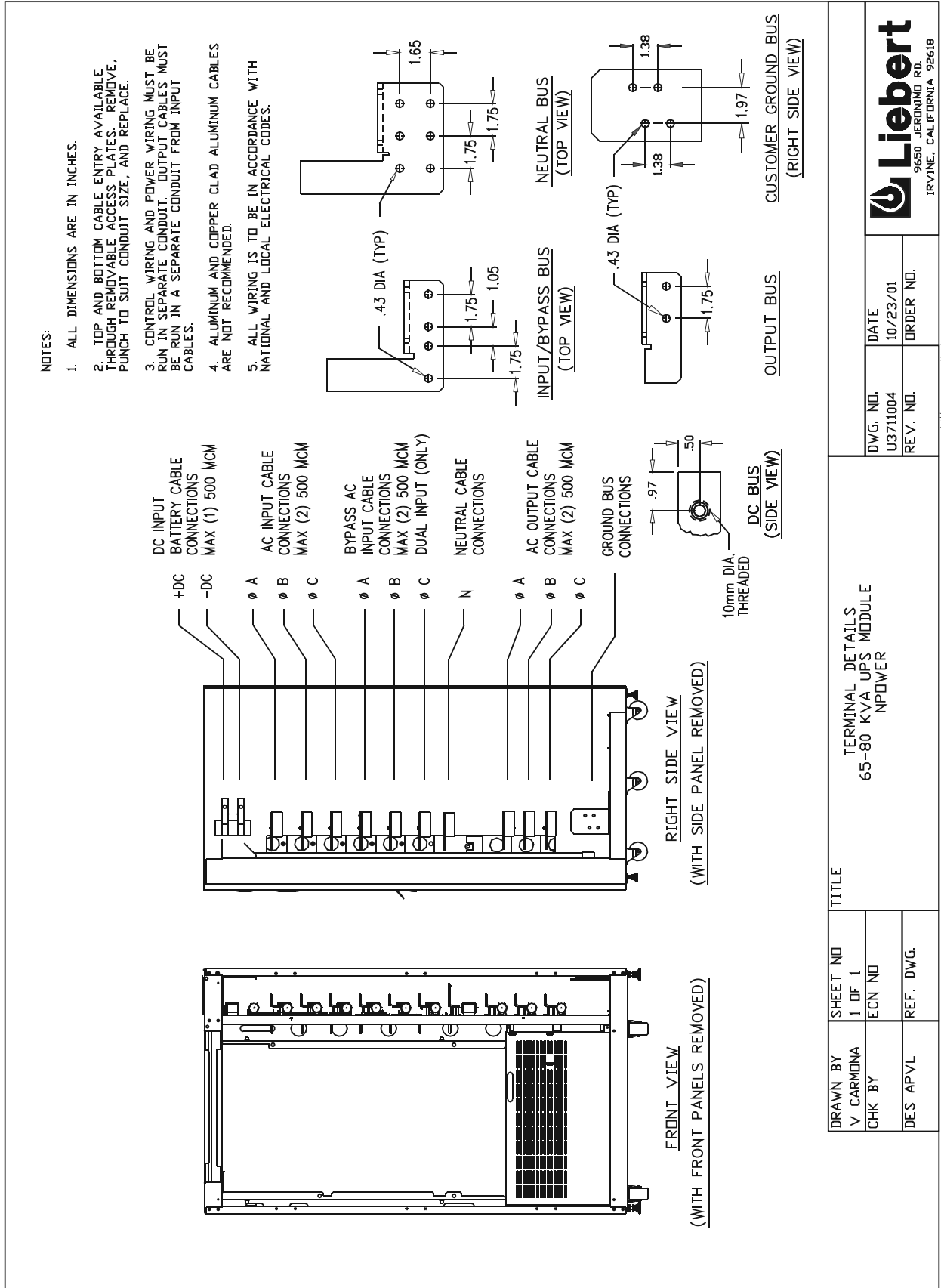


Figure 59 Terminal Details, 100 - 130 kVA UPS

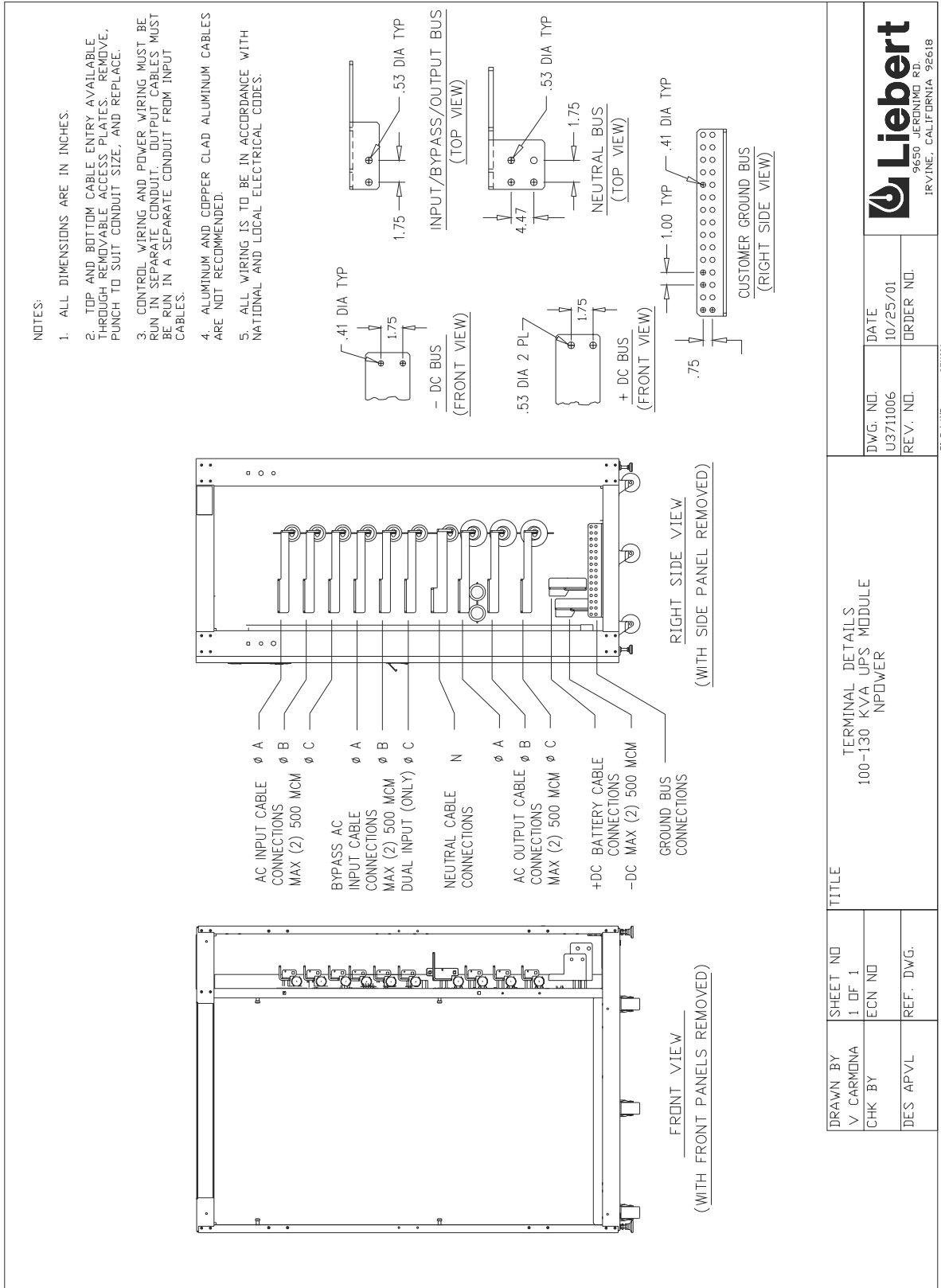
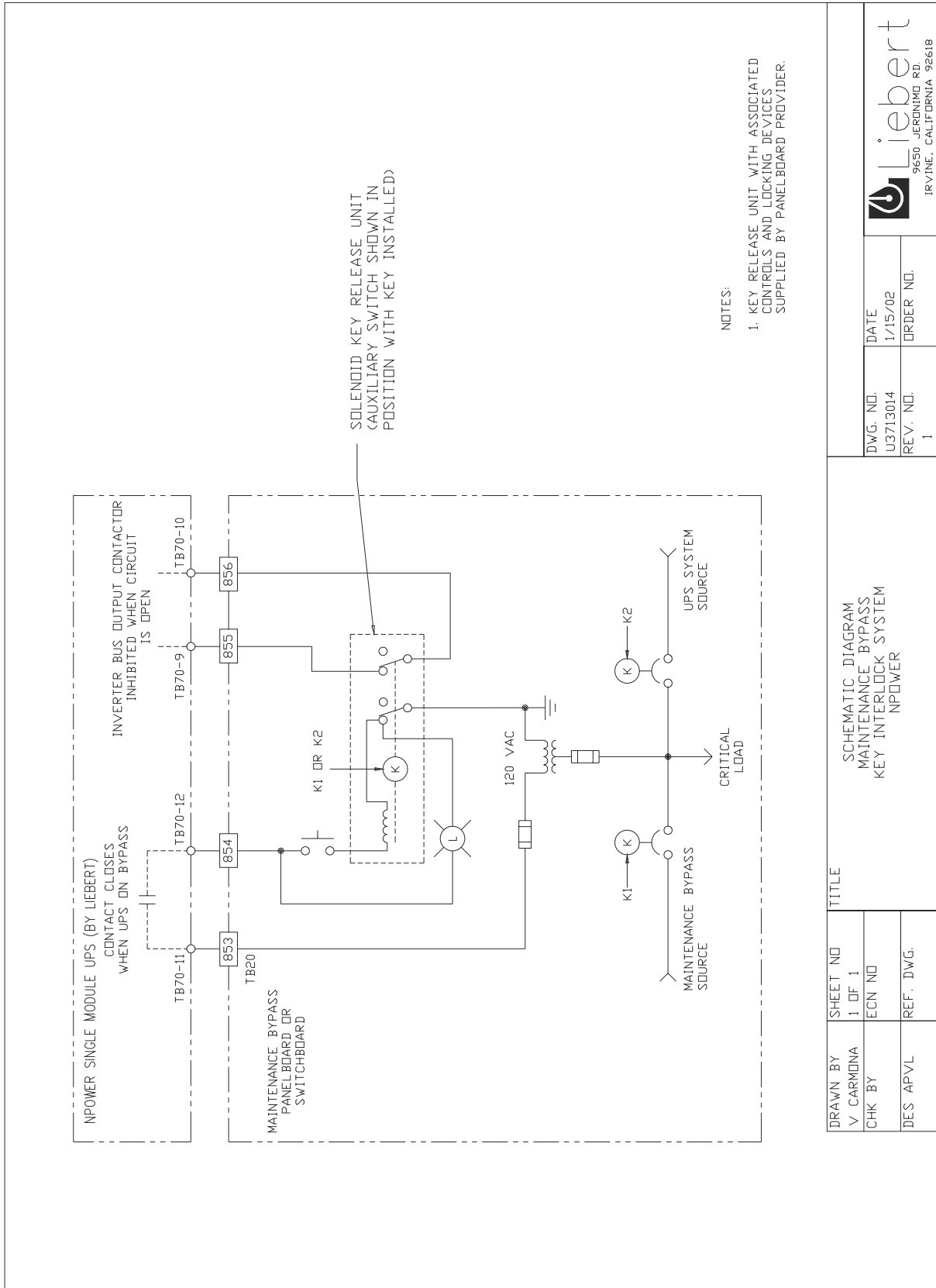


Figure 60 Schematic Diagram Maintenance Bypass Interlock System



DWG. NO. U3713014	DATE 1/15/02
REV. NO. 1	ORDER NO.

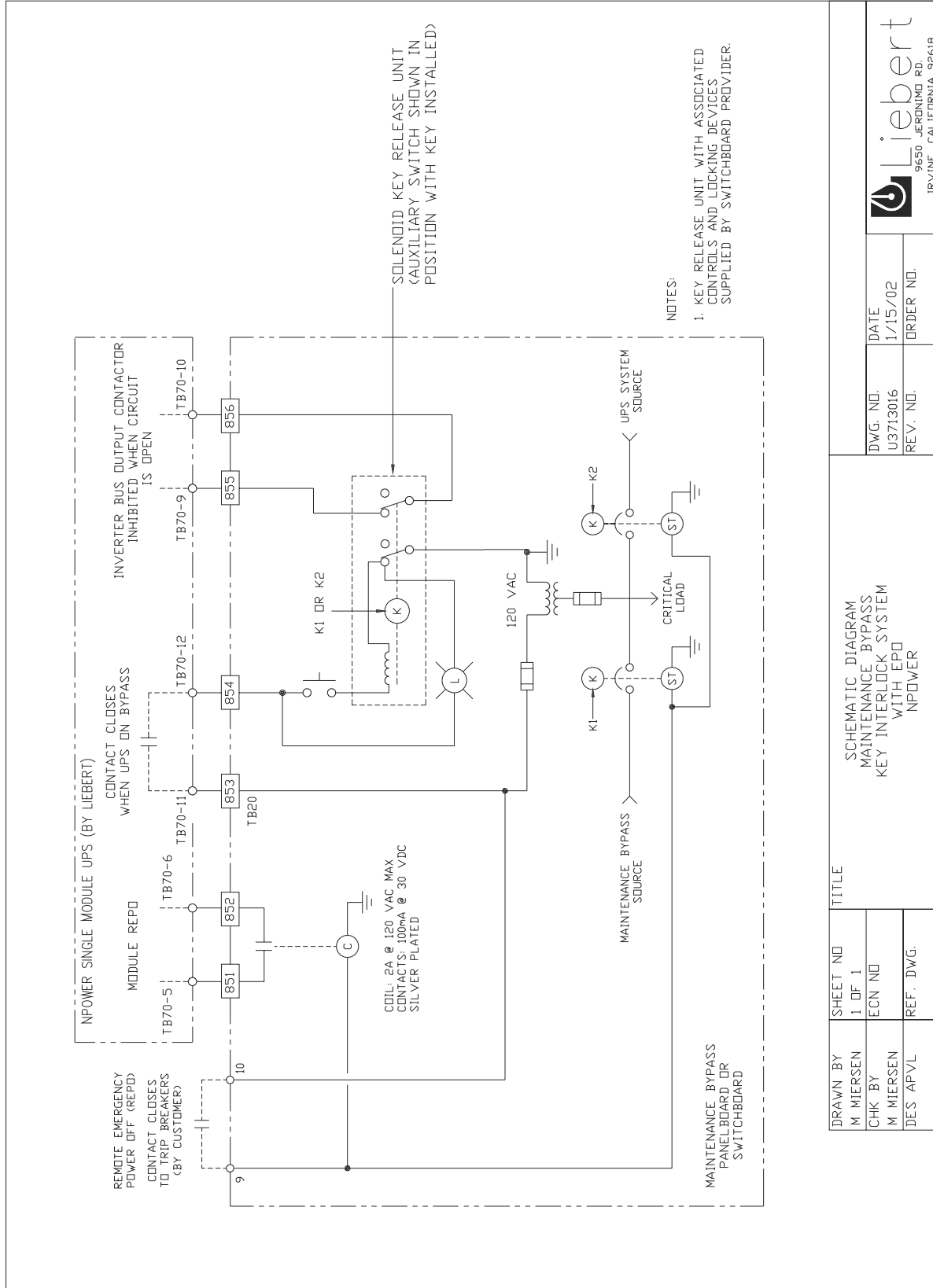
FILE NAME: IPT\IDMS\U3713014

TITLE SCHEMATIC DIAGRAM MAINTENANCE BYPASS KEY INTERLOCK SYSTEM NPOWER	
--	--

DRAWN BY V. CARMONA	SHEET NO 1 OF 1
CHK BY	ECN NO
DES. APVL	REF. DWG.



Figure 61 Schematic Diagram Maintenance Bypass Interlock System with EPO



DRAWN BY	M MIERSEN	SHEET NO	1 OF 1	TITLE	SCHEMATIC DIAGRAM MAINTENANCE BYPASS KEY INTERLOCK SYSTEM WITH EPO NPOWER		
CHK BY	M MIERSEN	ECN NO		DWG. NO.	U3713016	DATE	1/15/02
DES. APVL		REF. DWG.		REV. NO.		ORDER NO.	

FILE NAME: OPTIONS\U3713016

Liabert
9650 JERONIMO RD.
IRVINE, CALIFORNIA 92618

Figure 62 Line-Up Detail Maintenance Bypass and Distribution Cabinets

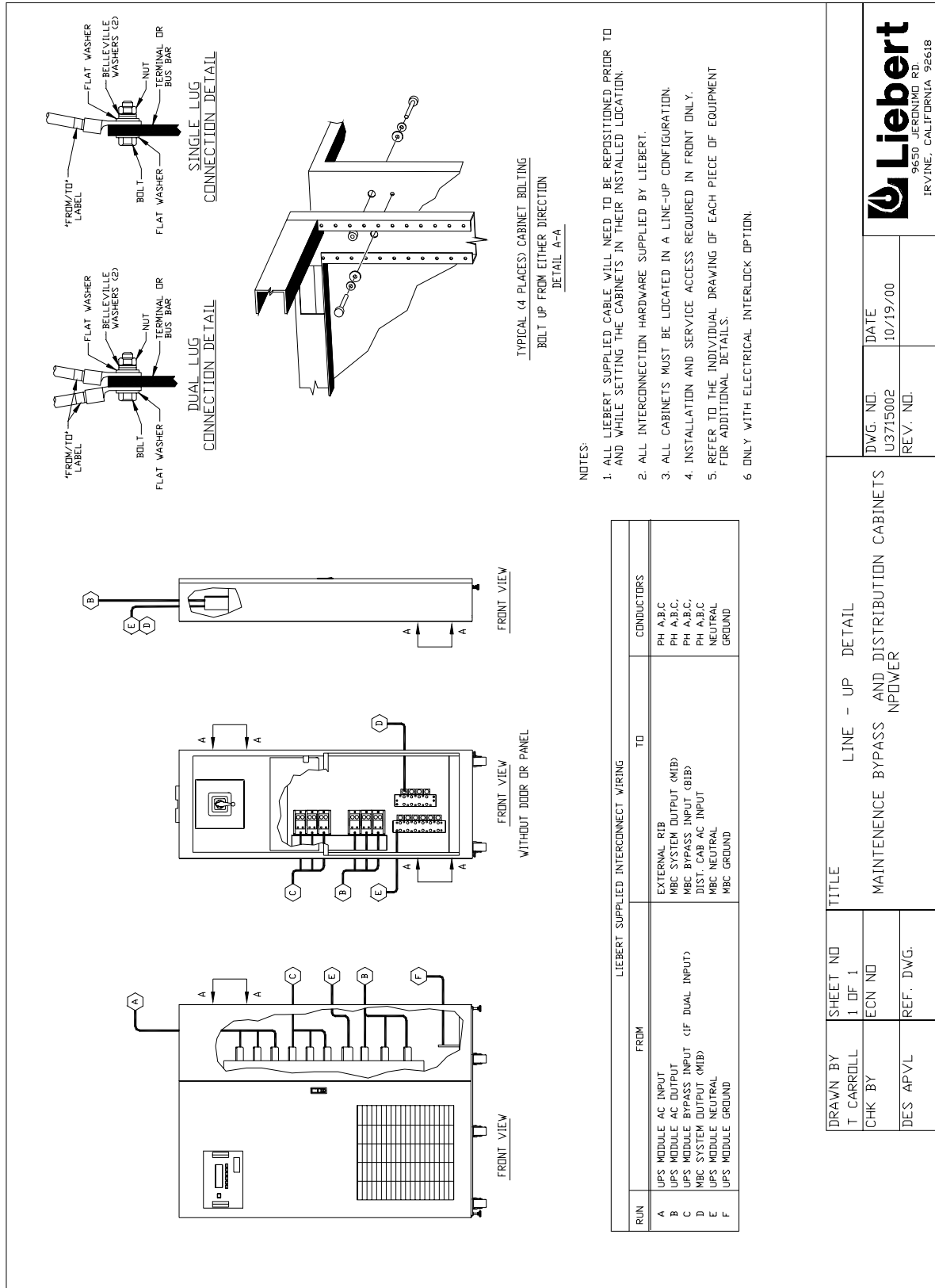
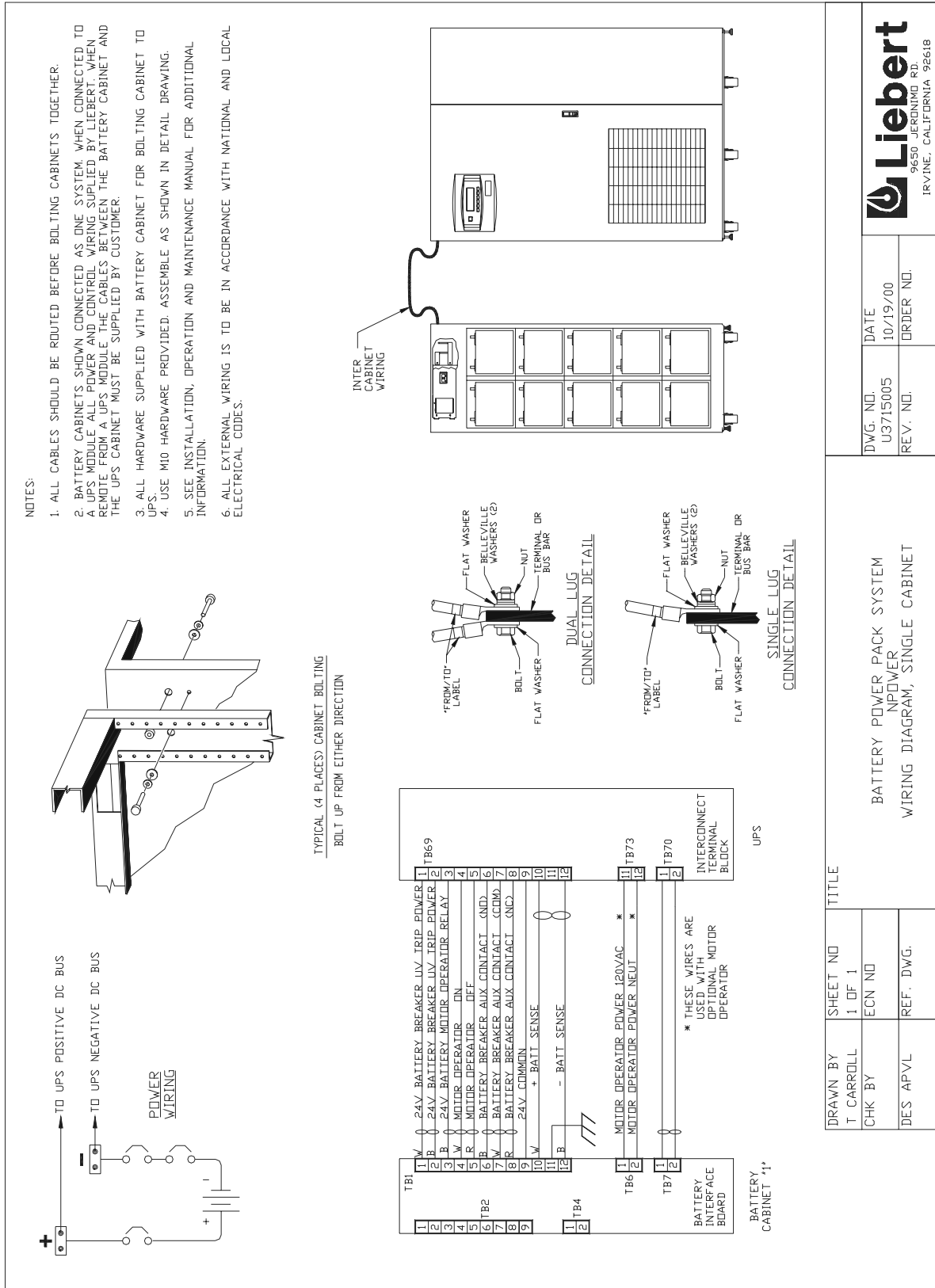


Figure 63 Wiring Diagram, UPS with Single Battery Cabinet



DRAWN BY T. CARROLL		SHEET NO 1 OF 1	TITLE BATTERY POWER PACK SYSTEM IN-POWER WIRING DIAGRAM, SINGLE CABINET	
CHK BY		ECN NO	DWG. NO. U3715005	DATE 10/19/00
DES: APVL		REF. DWG.	REV. NO.	ORDER NO.
			 9650 JERONIMO RD. IRVINE, CALIFORNIA 92618	

Figure 64 Interconnection Diagram, UPS Module with Multiple Battery Cabinets

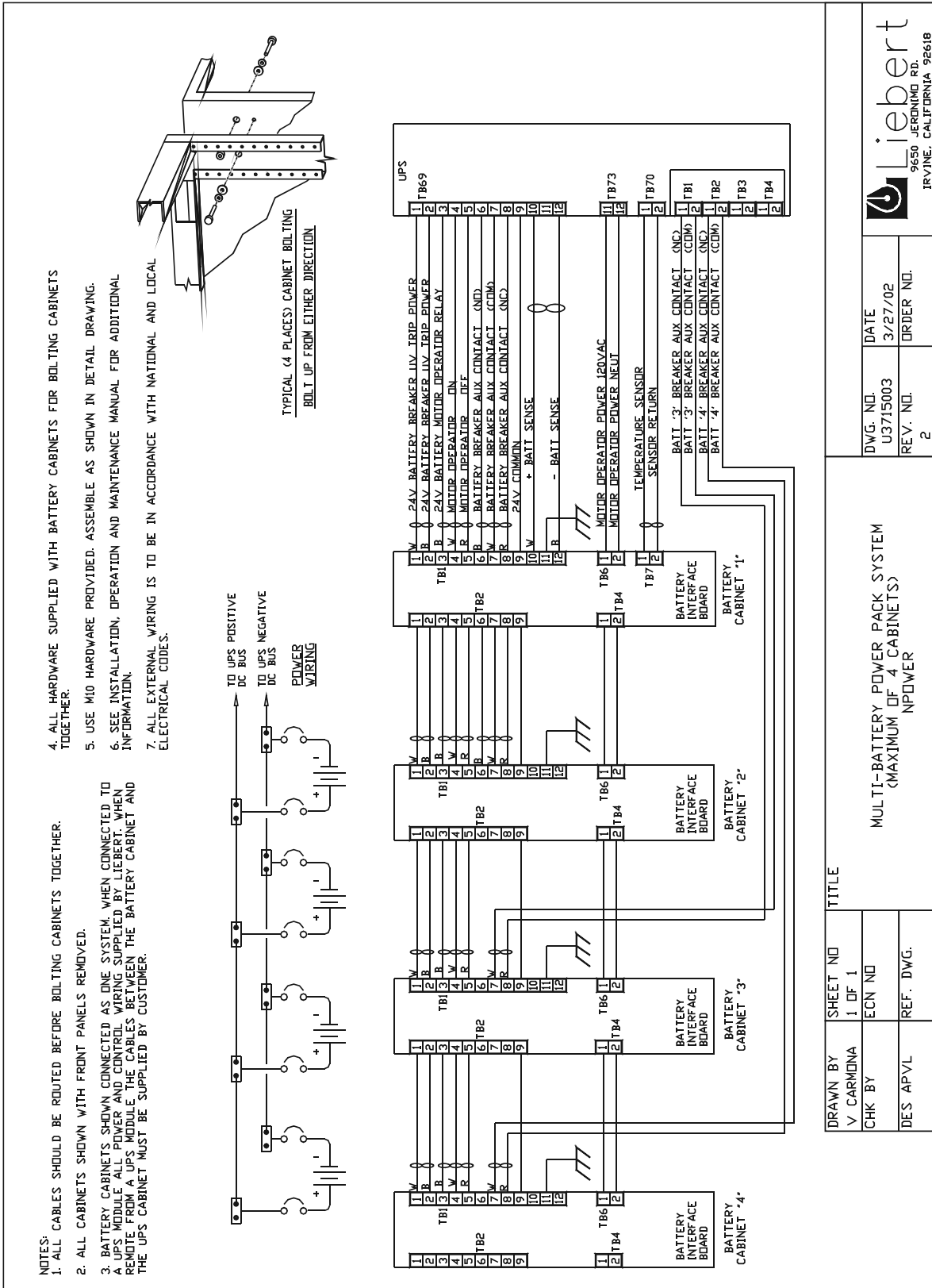


Figure 65 Circuit Breaker Schedule, Maintenance Bypass Cabinet, 30 - 130 kVA

- NOTES:
- 1 ALL BREAKERS ARE SQUARE D.
 - 2 BREAKER PART NUMBERS = PREFIX + 36 + AMPS + AA
 - 3 LETTER *P* IN P/N PREFIX INDICATES LUGS ON LOAD SIDE ONLY.

MBC BREAKER SCHEDULE											
		INPUT			BYPASS			OUTPUT			
kVA/kW	VOLTS	AMPS	PREFIX	AIC	AMPS	PREFIX	AIC	AMPS	PREFIX	AIC	
30/24	208	150	NFNM	65k	100	NFNM	65k	100	NFNP	65k	
	480	70	NFNM	35k	50	NFNM	35k	50	NFNP	35k	
	600	50	NFNM	18k	50	NFNM	18k	50	NFNP	18k	
40/32	208	200	NFNM	65k	150	NFNM	65k	150	NFNP	65k	
	480	100	NFNM	35k	70	NFNM	35k	70	NFNP	35k	
	600	70	NFNM	18k	50	NFNM	18k	50	NFNP	18k	
50/40	208	250	NFNM	65k	200	NFNM	65k	200	NFNP	65k	
	480	100	NFNM	35k	100	NFNM	35k	100	NFNP	35k	
	600	100	NFNM	18k	70	NFNM	18k	70	NFNP	18k	
65/52	208	300	NFNM	65k	250	NFNM	65k	250	NFNP	65k	
	480	150	NFNM	35k	100	NFNM	35k	100	NFNP	35k	
	600	100	NFNM	18k	100	NFNM	18k	100	NFNP	18k	
80/64	208	350	NFNM	65k	300	NFNM	65k	300	NJNP	65k	
	480	150	NFNM	35k	150	NFNM	35k	150	NFNP	35k	
	600	150	NFNM	18k	100	NFNM	18k	100	NFNP	18k	
100/80	208	450	NFNM	65k	350	NFNM	65k	350	NJNP	65k	
	480	200	NFNM	35k	150	NFNM	35k	150	NFNP	35k	
	600	150	NFNM	18k	150	NFNM	18k	150	NFNP	18k	
130/104	208	600	NFNM	65k	450	NFNM	65k	450	NJNP	65k	
	480	250	NFNM	35k	200	NFNM	35k	200	NFNP	35k	
	600	200	NFNM	18k	200	NFNM	18k	200	NFNP	18k	

DRAWN BY	SHEET NO
T CARROLL	1 OF 1
CHK BY	ECN NO
DES APVL	REF. DWG.

TITLE	
CIRCUIT BREAKER SCHEDULE MAINTENANCE BYPASS CABINET 30-130KVA NPPOWER	

DWG. NO.	DATE
U3715009	10/19/00
REV. NO.	



FILE NAME: LWP-UP03715009.DWG

Appendix A: Site Planning Data

480 or 208 VAC Input

UPS Rating	AC Voltage		Standard AC Input without Filter		AC Input with Filter Option		AC Output Current		Max. Battery Disch. (Amps)	Max. Heat Dissipation BTU/hr Full Load	Dimensions WxDxH (Inches)	Approx. Unpacked Weight (Pounds)	Concentrated Floor Loading (Lb/SqFt)	Cooling Air (CFM)	
	kVA	kW	Input	Output	Max	Norm	Max	Norm							Rec. OPD
30	24	208	208	114	150	80	99	125	83	125	32x32.5x71	2,200	307	720	
30	24	480	208	48	70	33	41	50	83	125	32x32.5x71	2,100	294	720	
30	24	480	480	38	70	33	41	50	36	50	32x32.5x71	1,900	265	720	
40	32	208	208	122	153	200	106	133	111	150	32x32.5x71	2,200	307	720	
40	32	480	208	51	64	90	44	55	111	150	32x32.5x71	2,100	294	720	
40	32	480	480	51	64	90	44	55	48	60	32x32.5x71	1,900	265	720	
50	40	208	208	153	191	250	133	166	139	175	32x32.5x71	2,200	307	720	
50	40	480	208	64	80	100	55	69	139	175	32x32.5x71	2,100	294	720	
50	40	480	480	64	80	100	55	69	60	80	32x32.5x71	1,900	265	720	
65	52	208	208	193	242	350	171	213	180	225	39x32.5x71	2,700	304	960	
65	52	480	208	80	99	150	70	88	180	225	39x32.5x71	2,500	284	960	
65	52	480	480	80	99	150	70	88	78	100	39x32.5x71	2,300	262	960	
80	64	208	208	238	298	400	210	262	222	300	39x32.5x71	2,700	304	960	
80	64	480	208	98	122	175	87	108	222	300	39x32.5x71	2,500	284	960	
80	64	480	480	98	122	175	87	108	96	125	39x32.5x71	2,300	262	960	
100	80	208	208	296	370	500	261	326	278	350	49x32.5x71	3,800	342	1440	
100	80	480	208	122	152	225	108	135	278	350	49x32.5x71	3,600	324	1440	
100	80	480	480	122	152	225	108	135	120	150	49x32.5x71	3,400	305	1440	
130	104	208	208	385	481	700	339	420	361	450	49x32.5x71	3,800	342	1440	
130	104	480	208	158	198	300	140	175	361	450	49x32.5x71	3,600	324	1440	
130	104	480	480	158	198	300	140	175	156	200	49x32.5x71	3,400	305	1440	
Notes:	1,3,4,5,7,8,9,11,12,13													14	—

Notes For Table:

- Nominal rectifier AC input current (considered continuous) is based on full rated output load. Maximum current includes nominal input current and maximum battery recharge current (considered noncontinuous). Continuous and noncontinuous current limit are defined in NEC 100. Maximum input current is controlled by current limit setting which is adjustable. Values shown are for maximum setting of 125%. Standard factory setting is 115%.
- Nominal AC output current (considered continuous) is based on full rated output load.
- OCPD=Overcurrent Protection Device.
- Feeder protection (by others in external equipment) for rectifier AC input and bypass AC input is recommended to be provided by separate overcurrent protection devices.
- UPS output load cables must be run in separate conduit from input cables.
- Power cable from module DC bus to battery should be sized for a total maximum 2.0 volt line drop (measured at the module) at maximum discharge current.
- Grounding conductors to be sized per NEC 250-122. Neutral conductors to be sized for full capacity for systems with 4-wire loads, 310-15 (b) (4), per NEC, and half capacity for systems with 3-wire loads.
- Rectifier AC Input: 3-phase, 3-wire, plus ground. AC Output to Load: 3-phase, 3 or 4-wire, plus ground. Bypass AC Input: 3-phase, 3 or 4-wire, plus ground. Module DC Input from Battery: 2-wire, (positive and negative).
- All wiring is to be in accordance with National and Local Electrical Codes.
- Minimum access clearance is 3 feet front and 1 foot above UPS.
- Top or bottom cable entry through removable access plates. Cut plate to suit conduit size. Conduit or wireway must not obstruct removal of top panels.
- Control wiring and power cables must be run in separate conduits. Control wiring must be stranded tinned conductors.
- 10% maximum input harmonic current and 0.92-0.95 lagging input power factor at full load with optional input filter.
- 30% maximum input harmonic current and 0.85 lagging input power factor at full load without optional input filter.
- Dimensions and weights shown do not include Battery Cabinet, Slim-Line Distribution Cabinet or other options.

Site Planning Data

600VAC Input

UPS Rating	AC Voltage		Standard AC Input without Filter		AC Input with Filter Option		AC Output Current		Max. Battery Disch. (Amps)	Max. Heat Dissipation BTU/hr Full Load	Dimensions WxDXH (inches)	Approx. Unpacked Weight (Pounds)	Concentrated Floor Loading (Lb/SqFt)	Cooling Air (CFM)	
	Input	Output	Max	Recommended	Max	Recommended	Nom	Recommended							
30	600	208	32	50	28	34	50	83	125	66A	31.7x32.5x71	2,200	307	720	
30	600	600	32	50	28	34	50	29	50	66A	31.7x32.5x71	2,200	307	720	
40	600	208	42	60	37	46	60	111	150	88A	31.7x32.5x71	2,200	307	720	
40	600	600	42	60	37	46	60	38	50	88A	31.7x32.5x71	2,200	307	720	
50	600	208	53	70	46	57	70	139	175	109A	31.7x32.5x71	2,100	307	720	
50	600	600	53	70	46	57	70	48	60	109A	31.7x32.5x71	1,900	307	720	
65	600	208	67	84	59	74	100	180	225	141A	39.4x32.5x71	2,200	304	960	
65	600	600	67	84	59	74	100	63	80	141A	39.4x32.5x71	2,100	304	960	
80	600	208	83	103	73	91	125	222	300	174A	39.4x32.5x71	1,900	304	960	
80	600	600	83	103	73	91	125	77	100	174A	39.4x32.5x71	2,700	304	960	
100	600	208	103	128	90	113	150	278	350	218A	49.2x32.5x71	2,500	342	1440	
100	600	600	103	128	90	113	150	96	125	218A	49.2x32.5x71	2,300	342	1440	
130	600	208	133	167	118	147	200	361	450	283A	49.2x32.5x71	2,700	342	1440	
130	600	600	133	167	118	147	200	125	175	283A	49.2x32.5x71	2,500	342	1440	
Notes:	1,3,4,5,7,8, 9,11,12, 13														
	2,3,5,7,8,9,11,12												14	—	—

Site Planning Data

220 OR 240 VAC INPUT

UPS Rating	AC Voltage		Standard AC Input without Filter		AC Input with Filter Option		AC Output Current		Max. Battery Disch. (Amps)	Max. Heat Dissipation BTU/hr Full Load	Dimensions WxDxH (Inches)	Approx. Unpacked Weight (Pounds)	Concentrated Floor Loading (Lb/SqFt)	Cooling Air (CFM)
	kVA	kW	Input	Output	Max	Recom-mended	Nom	Rec. OCPD						
30	24	220	87	108	75	94	83	125	26	66A	31.7x32.5x71	2,200	307	720
30	24	220	87	108	75	94	79	100	26	66A	31.7x32.5x71	2,200	307	720
30	24	240	79	99	69	86	83	125	26	66A	31.7x32.5x71	2,200	307	720
30	24	240	79	99	69	86	72	100	26	66A	31.7x32.5x71	2,200	307	720
40	32	220	115	144	100	125	111	150	34	88A	31.7x32.5x71	2,200	307	720
40	32	220	115	144	100	125	105	150	34	88A	31.7x32.5x71	2,200	307	720
40	32	240	106	132	92	115	111	150	34	88A	31.7x32.5x71	2,200	307	720
40	32	240	106	132	92	115	96	125	34	88A	31.7x32.5x71	2,200	307	720
50	40	220	144	180	125	157	139	175	43	109A	31.7x32.5x71	2,200	307	720
50	40	220	144	180	125	157	131	175	43	109A	31.7x32.5x71	2,200	307	720
50	40	240	132	165	115	144	139	175	43	109A	31.7x32.5x71	2,200	307	960
50	40	240	132	165	115	144	120	150	43	109A	31.7x32.5x71	2,200	307	960
65	52	220	183	229	161	202	180	225	55	141A	39.4x32.5x71	2,700	304	960
65	52	220	183	229	161	202	171	225	55	141A	39.4x32.5x71	2,700	304	960
65	52	240	168	210	148	185	180	225	55	141A	39.4x32.5x71	2,700	304	960
65	52	240	168	210	148	185	156	200	55	141A	39.4x32.5x71	2,700	304	960
80	64	220	225	281	198	248	222	300	68	174A	39.4x32.5x71	2,700	304	960
80	64	220	225	281	198	248	210	300	68	174A	39.4x32.5x71	2,700	304	960
80	64	240	206	258	182	227	222	300	68	174A	39.4x32.5x71	2,700	304	960
80	64	240	206	258	182	227	192	250	68	174A	39.4x32.5x71	2,700	304	960
100	80	220	280	350	247	308	278	350	85	218A	49.2x32.5x71	3,800	342	1440
100	80	220	280	350	247	308	262	350	85	218A	49.2x32.5x71	3,800	342	1440
100	80	240	256	321	226	283	278	350	85	218A	49.2x32.5x71	3,800	342	1440
100	80	240	256	321	226	283	241	300	85	218A	49.2x32.5x71	3,800	342	1440
130	104	220	364	455	321	401	361	450	111	283A	49.2x32.5x71	3,800	342	1440
130	104	220	364	455	321	401	341	450	111	283A	49.2x32.5x71	3,800	342	1440
130	104	240	333	417	294	368	361	450	111	283A	49.2x32.5x71	3,800	342	1440
130	104	240	333	417	294	368	313	400	111	283A	49.2x32.5x71	3,800	342	1440
Notes:	1,3,4,5,7,8,9,11,12,13											14	—	—

Npower™ UPS

INSTALLATION MANUAL

The Company Behind the Products

With over a million installations around the globe, Liebert is the world leader in computer protection systems. Since its founding in 1965, Liebert has developed a complete range of support and protection systems for sensitive electronics:

- Environmental systems—close-control air conditioning from 1 to 60 tons
- Power conditioning and UPS with power ranges from 300 VA to more than 1000 kVA
- Integrated systems that provide both environmental and power protection in a single, flexible package
- Monitoring and control—from systems of any size or location, on-site or remote
- Service and support through more than 100 service centers around the world and a 24/7 Customer Response Center

While every precaution has been taken to ensure the accuracy and completeness of this literature, Liebert Corporation assumes no responsibility and disclaims all liability for damages resulting from use of this information or for any errors or omissions.

© 2003 Liebert Corporation
All rights reserved throughout the world.
Specifications subject to change without notice.

® Liebert and the Liebert logo are registered trademarks of Liebert Corporation. All names referred to are trademarks or registered trademarks of their respective owners.

SL-24532 Revision 4 (July 03)

Technical Support/Service

Web Site
www.liebert.com

Monitoring
800-222-5877
monitoring@liebert.com
Outside the US: 614-841-6755

Single-Phase UPS
800-222-5877
upstech@liebert.com
Outside the US: 614-841-6755

Three-Phase UPS
800-543-2378
powertech@liebert.com

Environmental Systems
800-543-2778
Outside the United States
614-888-0246

Locations

United States
1050 Dearborn Drive
P.O. Box 29186
Columbus, OH 43229

Italy
Via Leonardo Da Vinci 8
Zona Industriale Tognana
35028 Piove Di Sacco (PD)
+39 049 9719 111
Fax: +39 049 5841 257

Asia
23F, Allied Kajima Bldg.
138 Gloucester Road
Wanchai
Hong Kong
+852 2 572 2201
Fax: +852 2 831 0114